



Diffusion de Neutrons aux Petits Angles et Matière 'Dure'

Nicolas Martin

Laboratoire Léon Brillouin – UMR 12 CEA-CNRS

&

Fédération Française de Diffusion Neutronique

Small Angle Neutron Scattering

Applications in 'hard' condensed matter

- ✓ 'Hard matter' \equiv solid state physics
- ✓ $\approx 1/3$ of requested beam time at reactor facilities

Small Angle Neutron Scattering

Applications in 'hard' condensed matter

- ✓ 'Hard matter' \equiv solid state physics
- ✓ $\approx 1/3$ of requested beam time at reactor facilities
- ✓ Main area:
 - Material science \longrightarrow Grain size distribution, strains, porosity, phase separation, precipitates, *etc.*
 - Superconductivity
 - Magnetism



Small Angle Neutron Scattering

Applications in 'hard' condensed matter

- ✓ 'Hard matter' \equiv solid state physics
- ✓ $\approx 1/3$ of requested beam time at reactor facilities
- ✓ Main area:
 - Material science
 - Superconductivity \longrightarrow Morphology of flux line lattices
 - Magnetism

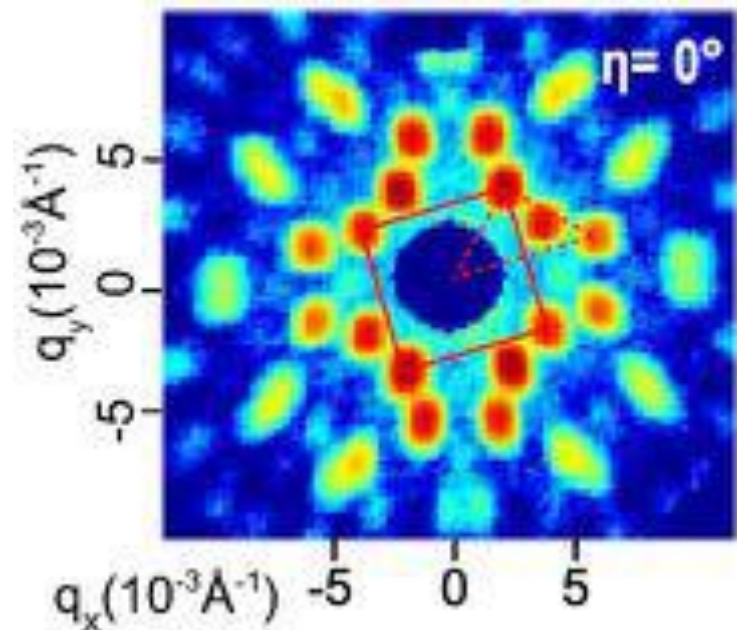
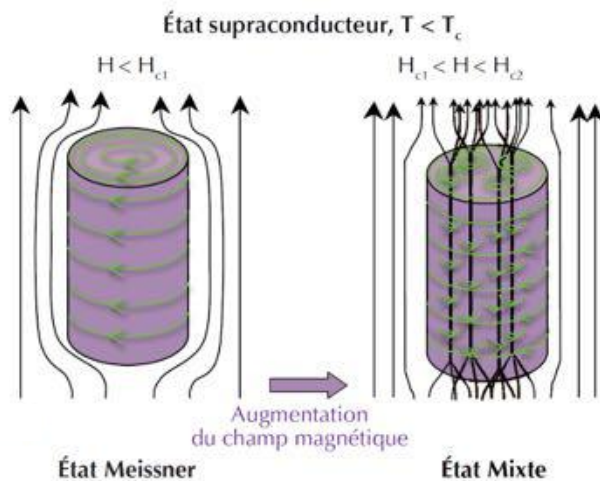

Small Angle Neutron Scattering

Applications in 'hard' condensed matter

- ✓ 'Hard matter' \equiv solid state physics
- ✓ $\approx 1/3$ of requested beam time at reactor facilities
- ✓ Main area:

- Material science
- Superconductivity
- Magnetism

—————→ Magnetic nanoparticles, long-period magnetic structures (helices, cycloids), topological defects, *etc.*

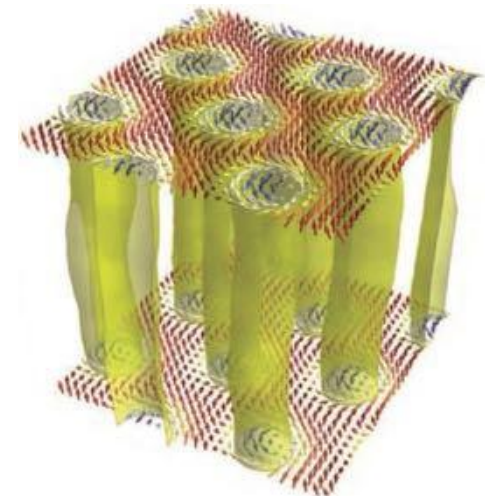
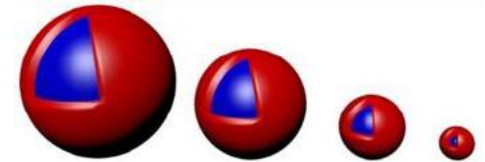

SANS for 'hard condensed matter'

Content of the talk

1. Magnetic (small angle) neutron scattering
2. Small angle diffraction
3. Magnetic form factor measurement
4. Inelastic scattering
5. Advanced SANS techniques

SANS for 'hard condensed matter'

Content of the talk

1. Magnetic (small angle) neutron scattering
2. Small angle diffraction
3. Magnetic form factor measurement
4. Inelastic scattering
5. Advanced SANS techniques

Magnetic scattering

Basic facts

- ✓ Wavelength in the Å range → Probe structures with 1-100 nm characteristic sizes/correlation length at small angle
- ✓ High penetration power → Probe bulk samples
- ✓ Spin 1/2 → Probe magnetic moments within the sample

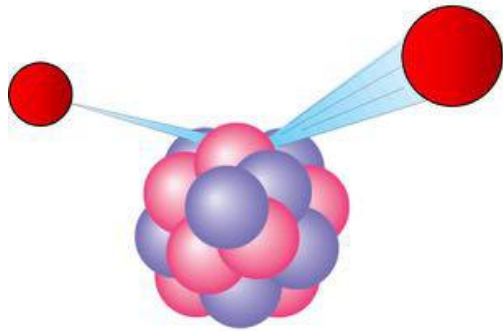

Nuclear scattering

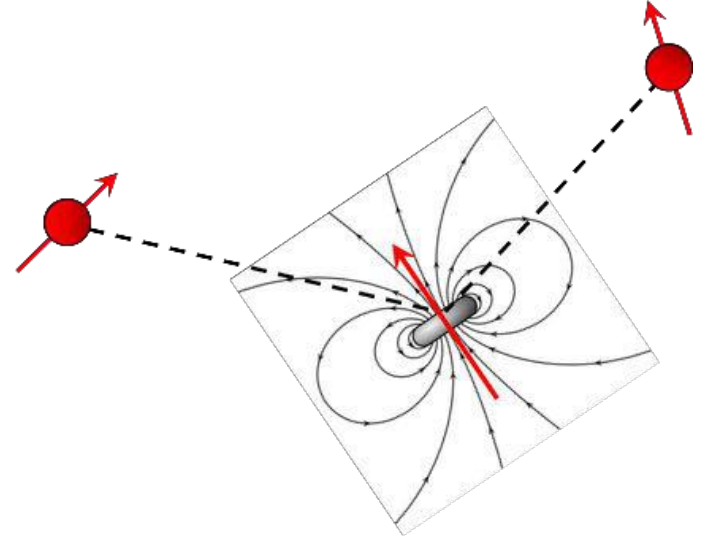

Magnetic scattering

Magnetic neutron scattering

Basic facts

- ✓ Dipole-dipole interaction → Magnetic scattering obeys **selection rules**

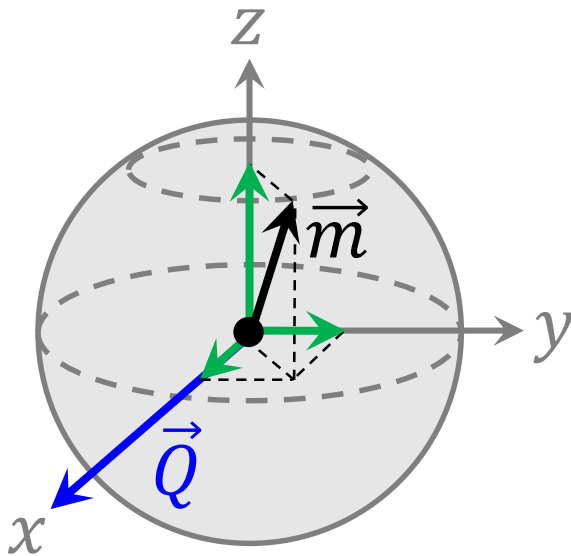

	n	m_x	m_y	m_z
$\vec{P} \parallel \vec{x}$	✓	✗	✓	✓
$\vec{P} \parallel \vec{y}$	✓	✗	✓	✓
$\vec{P} \parallel \vec{z}$	✓	✗	✓	✓

Magnetic neutron scattering

Basic facts

- ✓ Dipole-dipole interaction → Magnetic scattering obeys **selection rules**

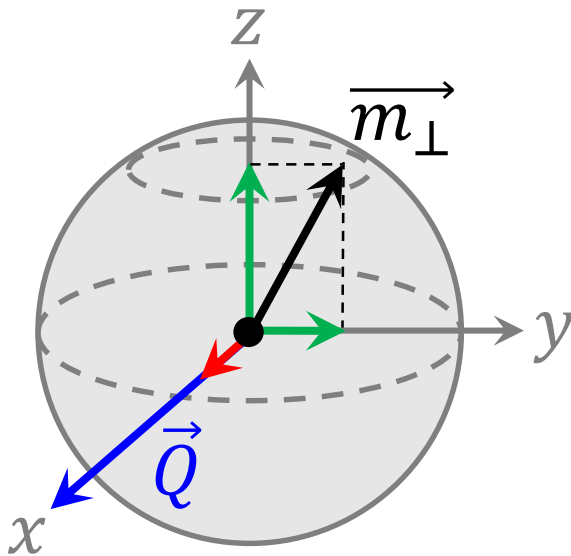

	n	m_x	m_y	m_z
$\vec{P} \parallel \vec{x}$	✓	✗	✓	✓
$\vec{P} \parallel \vec{y}$	✓	✗	✓	✓
$\vec{P} \parallel \vec{z}$	✓	✗	✓	✓

Magnetic neutron scattering

Basic facts

- ✓ Dipole-dipole interaction → Magnetic scattering obeys **selection rules**
- ✓ Polarized neutrons → Separate nuclear and magnetic contributions, reveal chirality, *etc.*

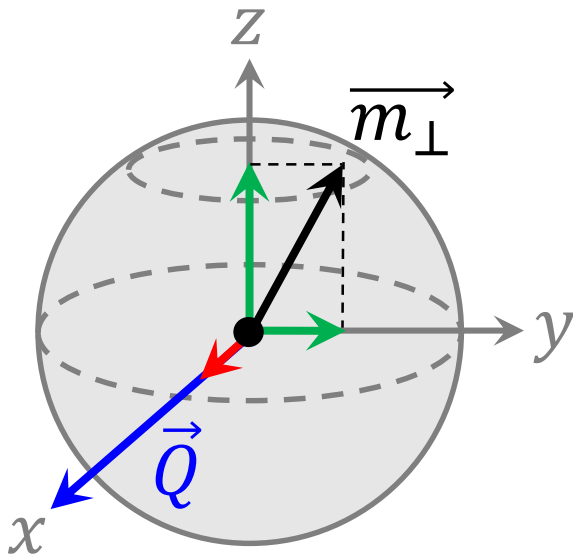

	n		m_x	m_y		m_z	
$\vec{P} \parallel \vec{x}$	✓	↑↑	✗	✓	↑↓	✓	↑↓
$\vec{P} \parallel \vec{y}$	✓	↑↑	✗	✓	↑↑	✓	↑↓
$\vec{P} \parallel \vec{z}$	✓	↑↑	✗	✓	↑↓	✓	↑↑

Magnetic neutron scattering

Quick examples

- ✓ Scattering off a monodomain helimagnet

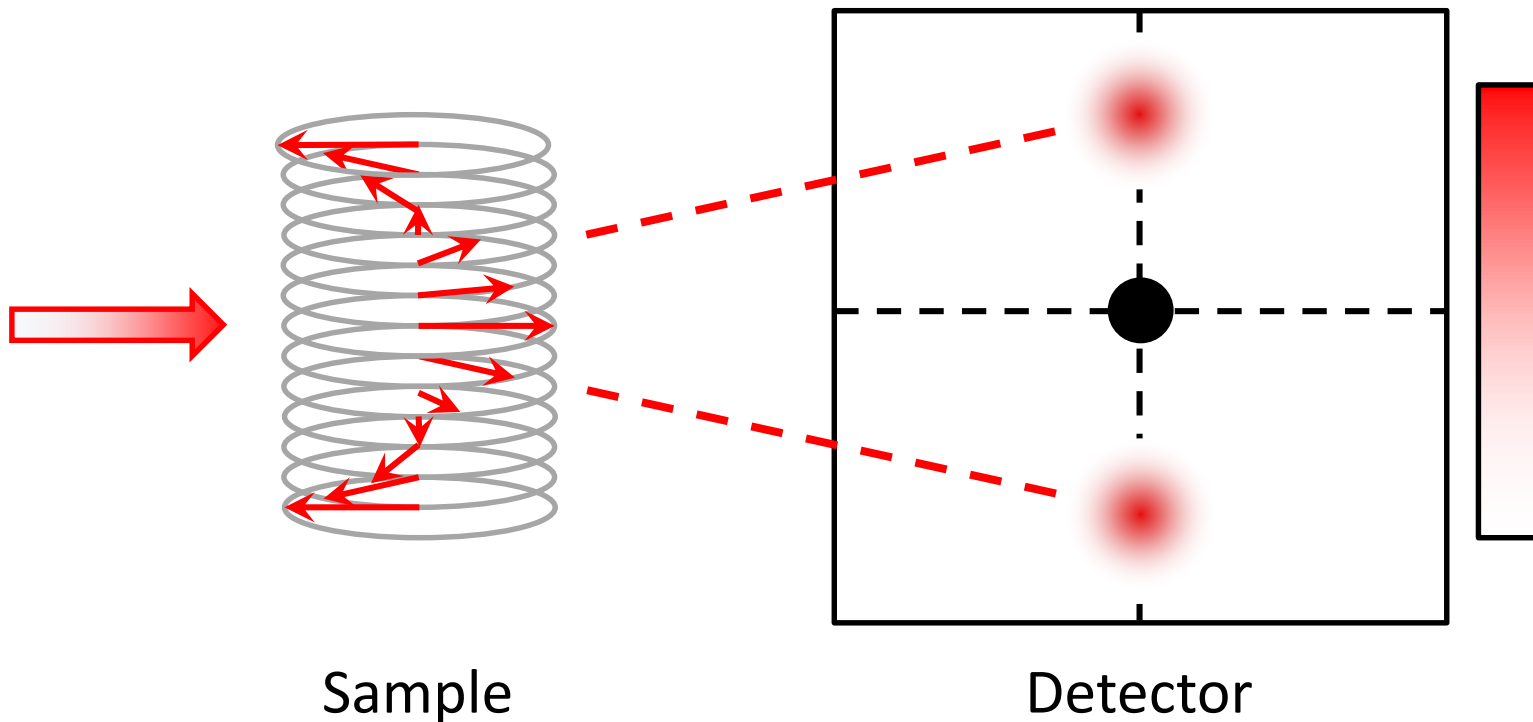

Magnetic neutron scattering

Quick examples

- ✓ Scattering off a monodomain helimagnet

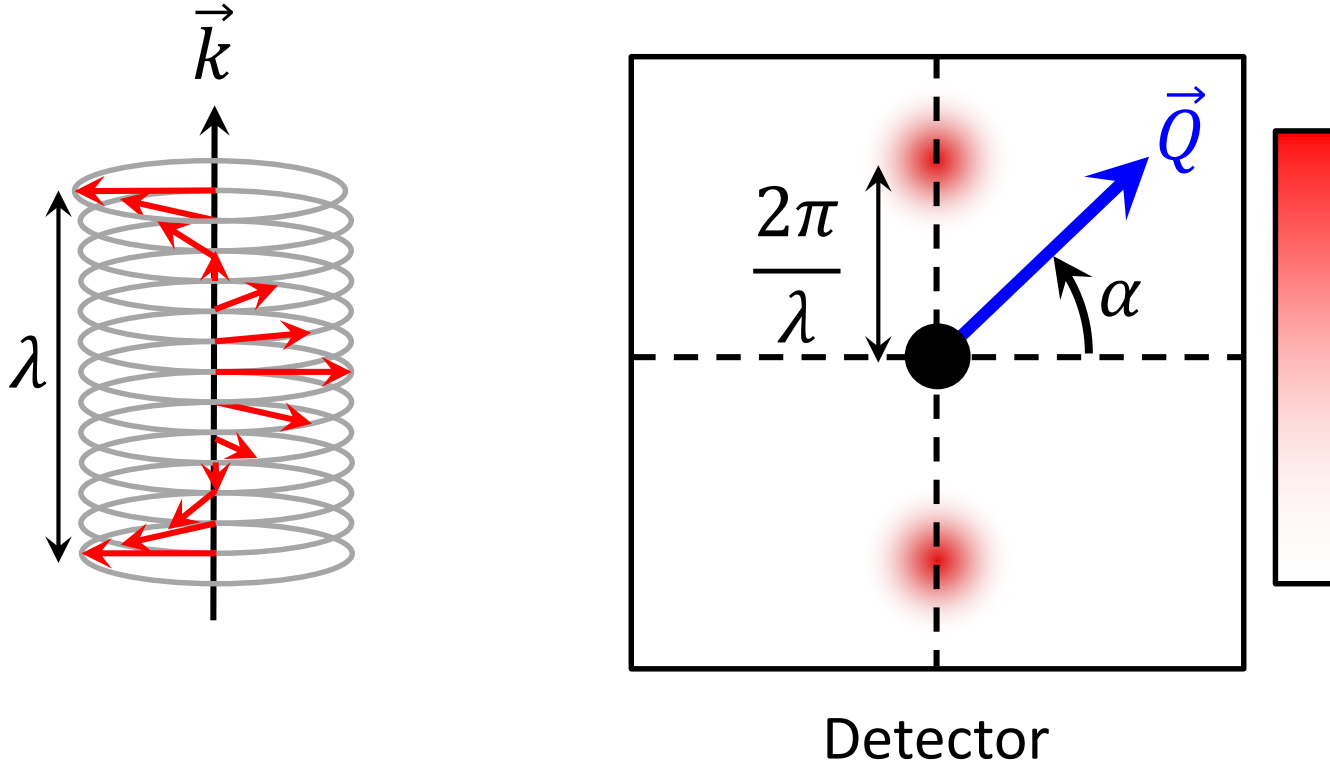

Magnetic neutron scattering

Quick examples

- ✓ Scattering off a monodomain helimagnet

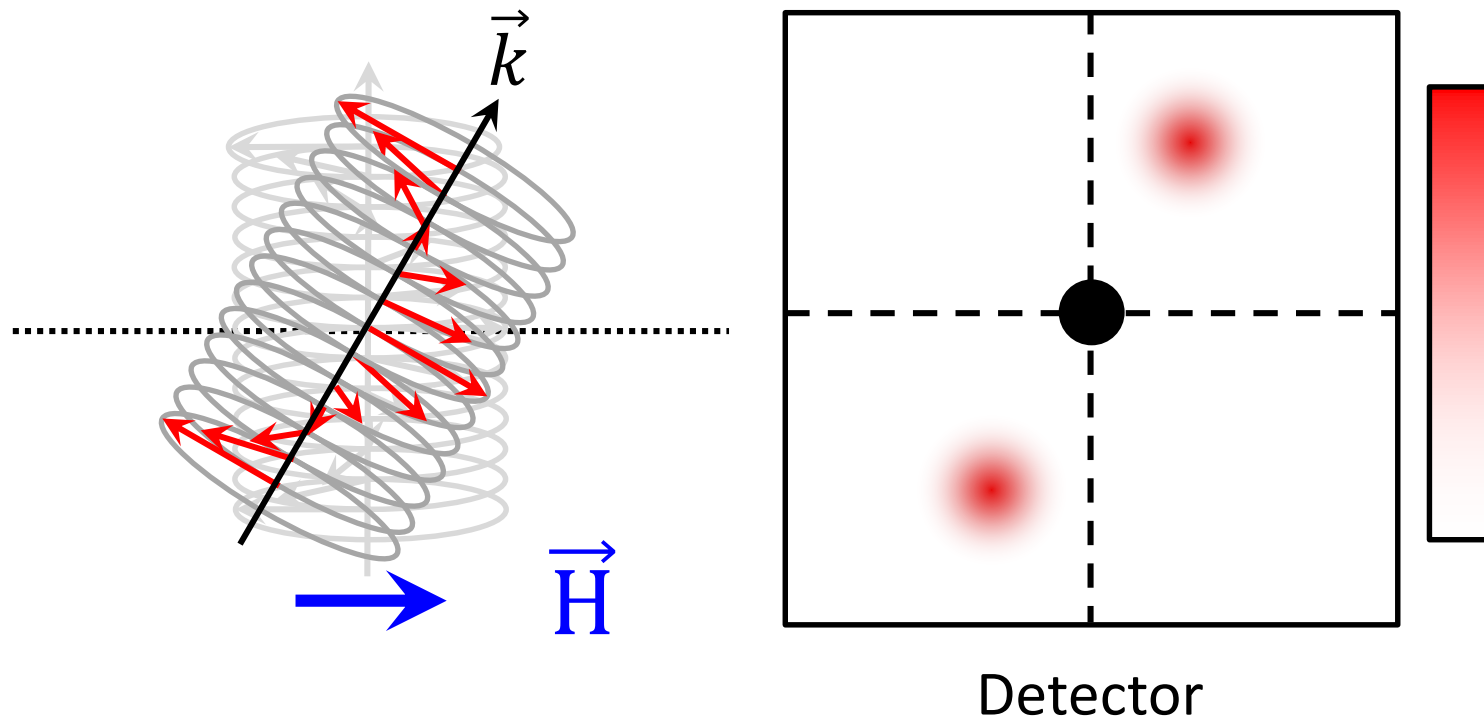

Magnetic neutron scattering

Quick examples

- ✓ Scattering off a monodomain helimagnet

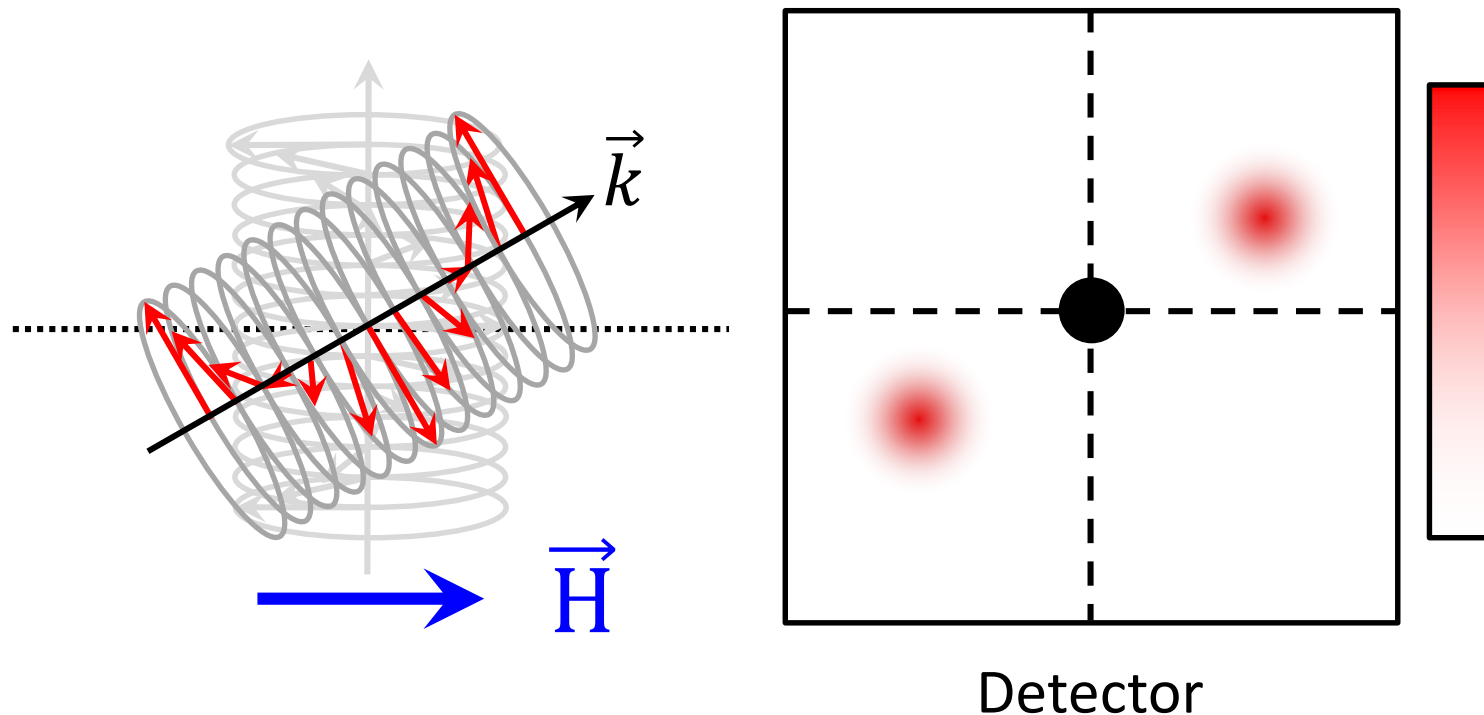

Magnetic neutron scattering

Quick examples

- ✓ Scattering off a monodomain helimagnet

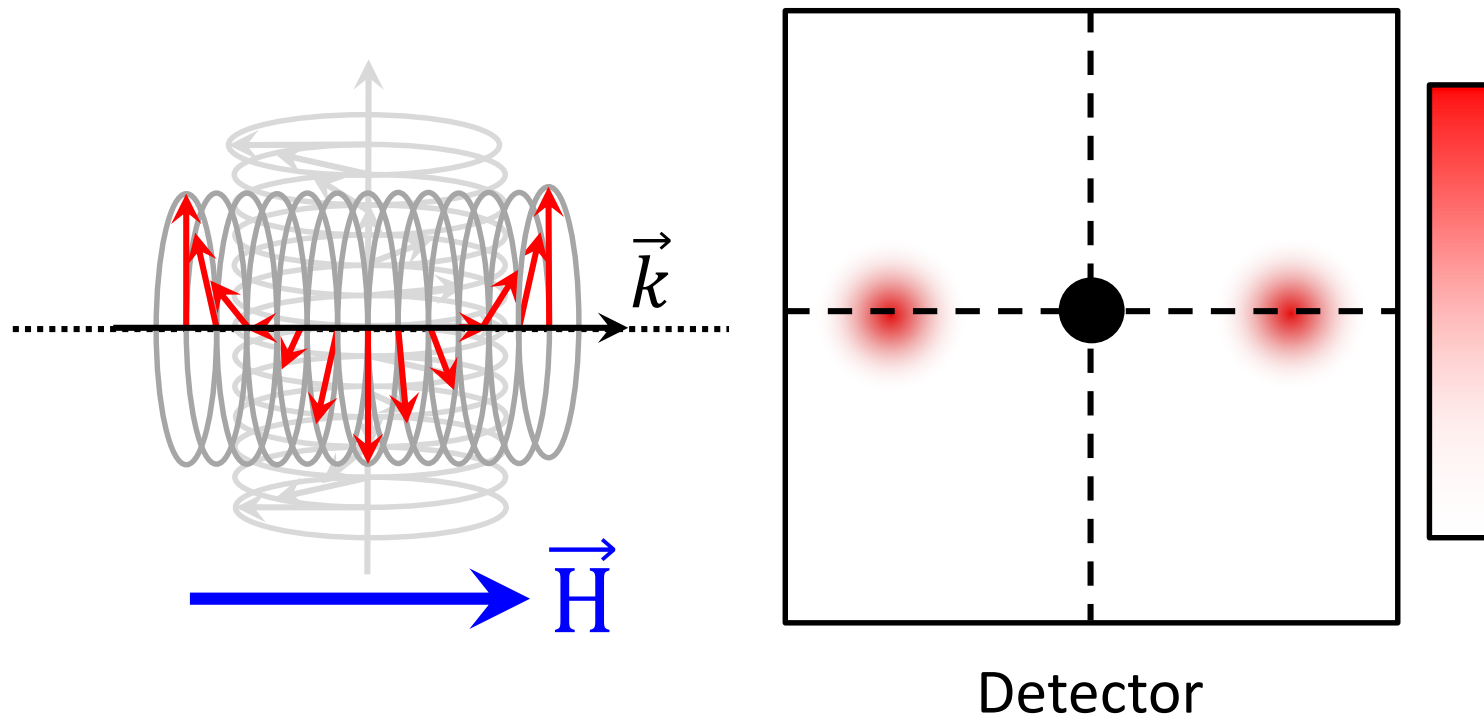

Magnetic neutron scattering

Quick examples

- ✓ Scattering off a monodomain helimagnet (with polarized neutrons)

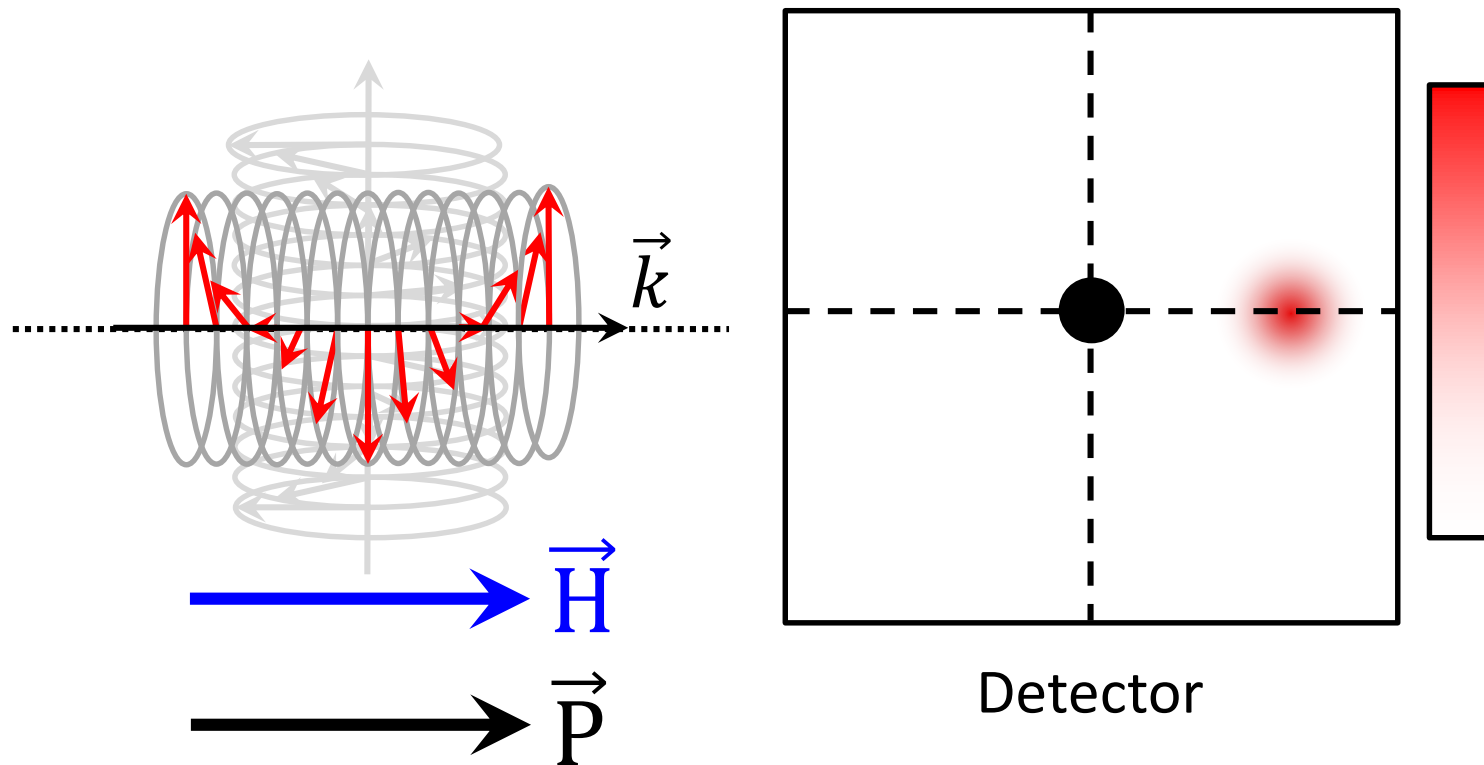

Magnetic neutron scattering

Quick examples

- ✓ Scattering off a monodomain helimagnet (with polarized neutrons)

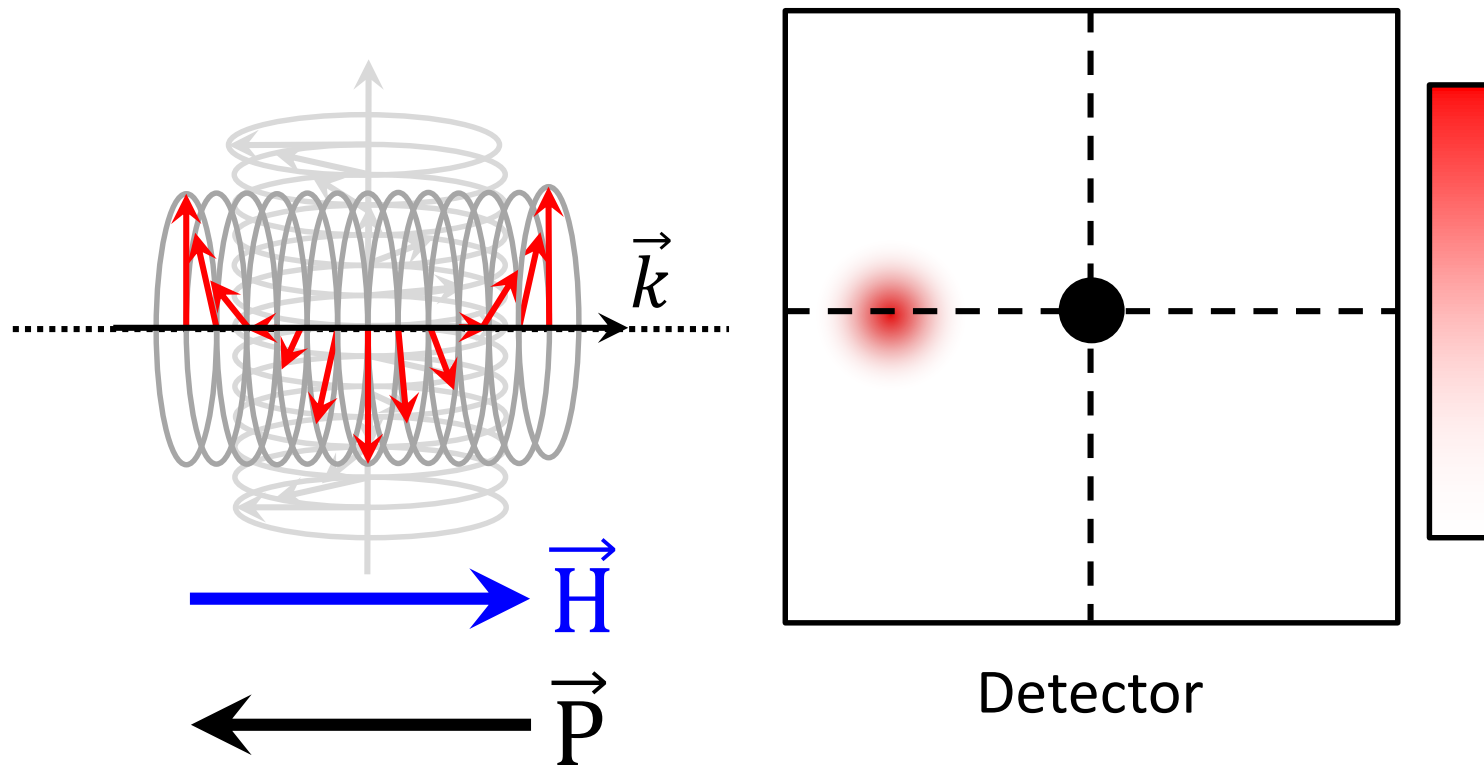

Magnetic neutron scattering

Quick examples

- ✓ Scattering off a multidomain helimagnet (powder)

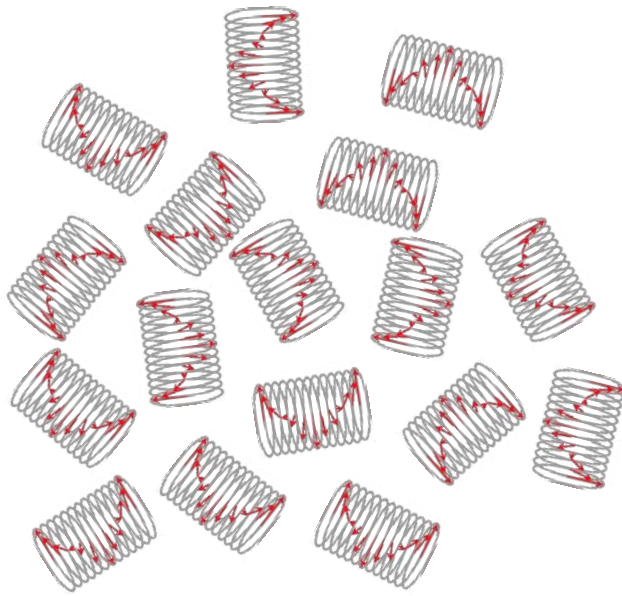

Sample

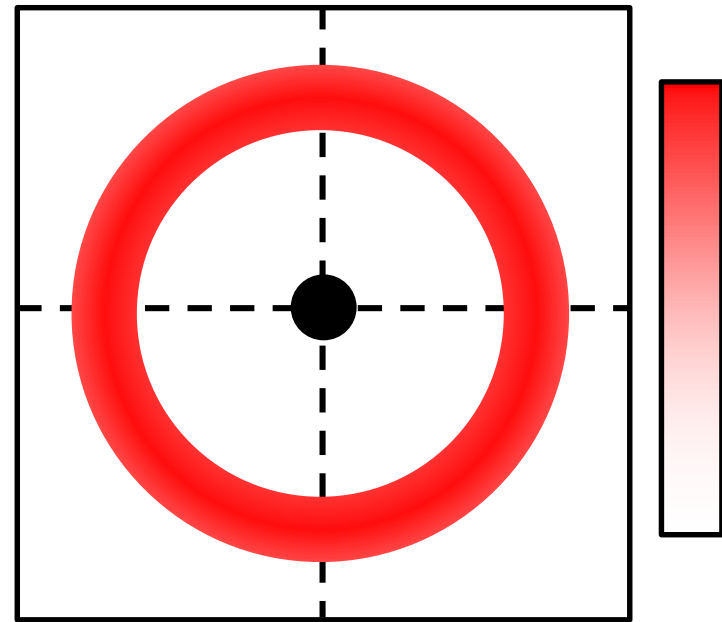

Detector

Magnetic neutron scattering

Sample environment



- Superconducting magnet (Oxford):
 - $T = 2 \rightarrow 300$ K
 - $H = 0 \rightarrow 10$ T (horizontal)

Magnetic neutron scattering

Sample environment

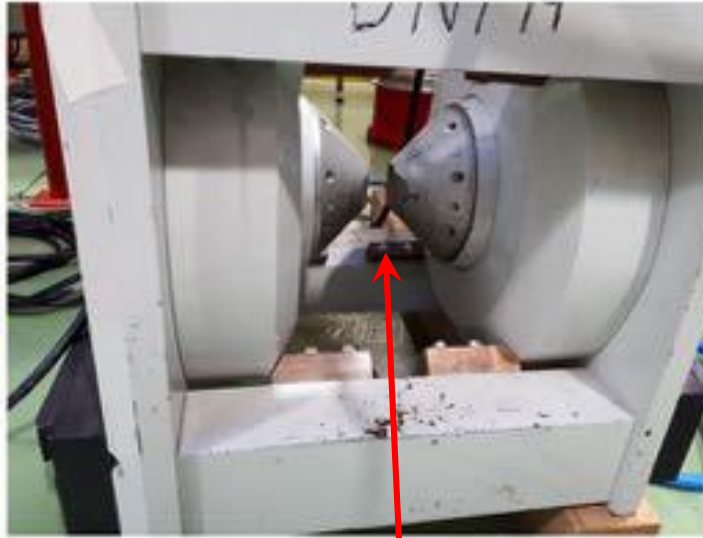
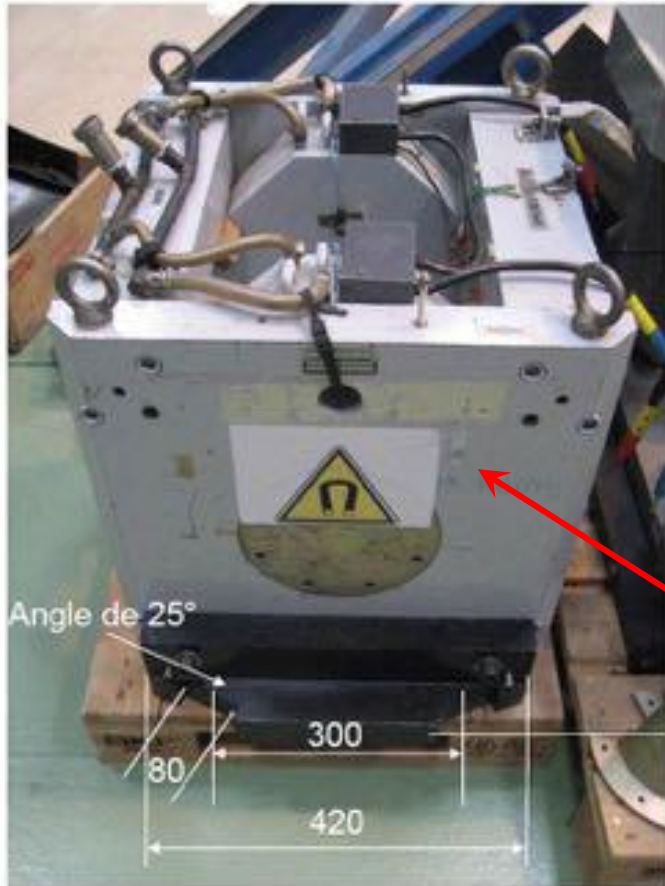

60 A water-cooled
electromagnet
+
10 K cryocooler
(ARS)



Magnetic neutron scattering

Sample environment

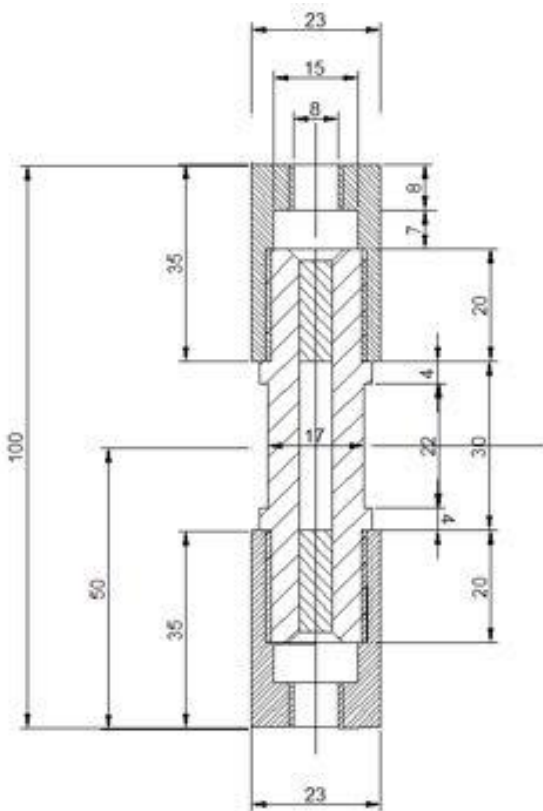

- Amagnetic clamp pressure cell (R. Sadykov, Russia):
 - $p = 0 \rightarrow 1.5 \text{ Gpa}$
 - Sample volume up to 600 mm^3
 - $T = 2 \rightarrow 300 \text{ K}$
 - $H = 0 \rightarrow 10 \text{ T}$

SANS for 'hard condensed matter'

Content of the talk

1. Magnetic (small angle) neutron scattering
- 2. Small angle diffraction**
3. Magnetic form factor measurement
4. Inelastic scattering
5. Advanced SANS techniques

Small-angle diffraction

Principles

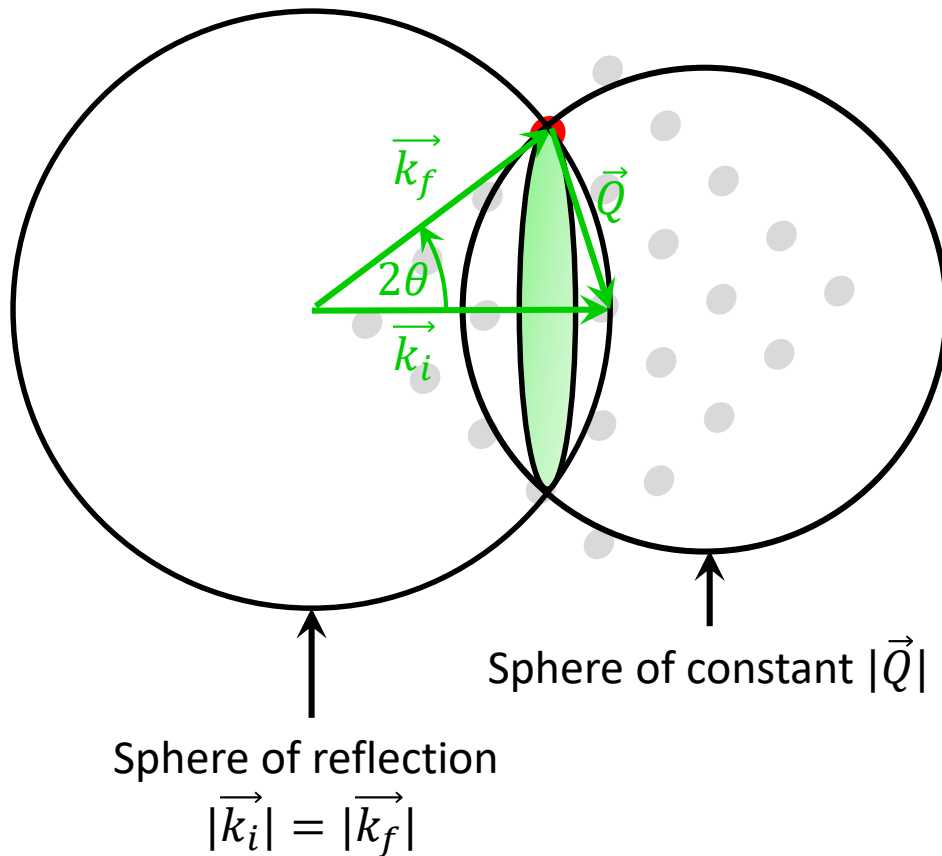

Bragg's law:

$$\theta = \arcsin\left(\frac{\lambda \cdot Q}{4\pi}\right)$$

Small-angle diffraction

Principles

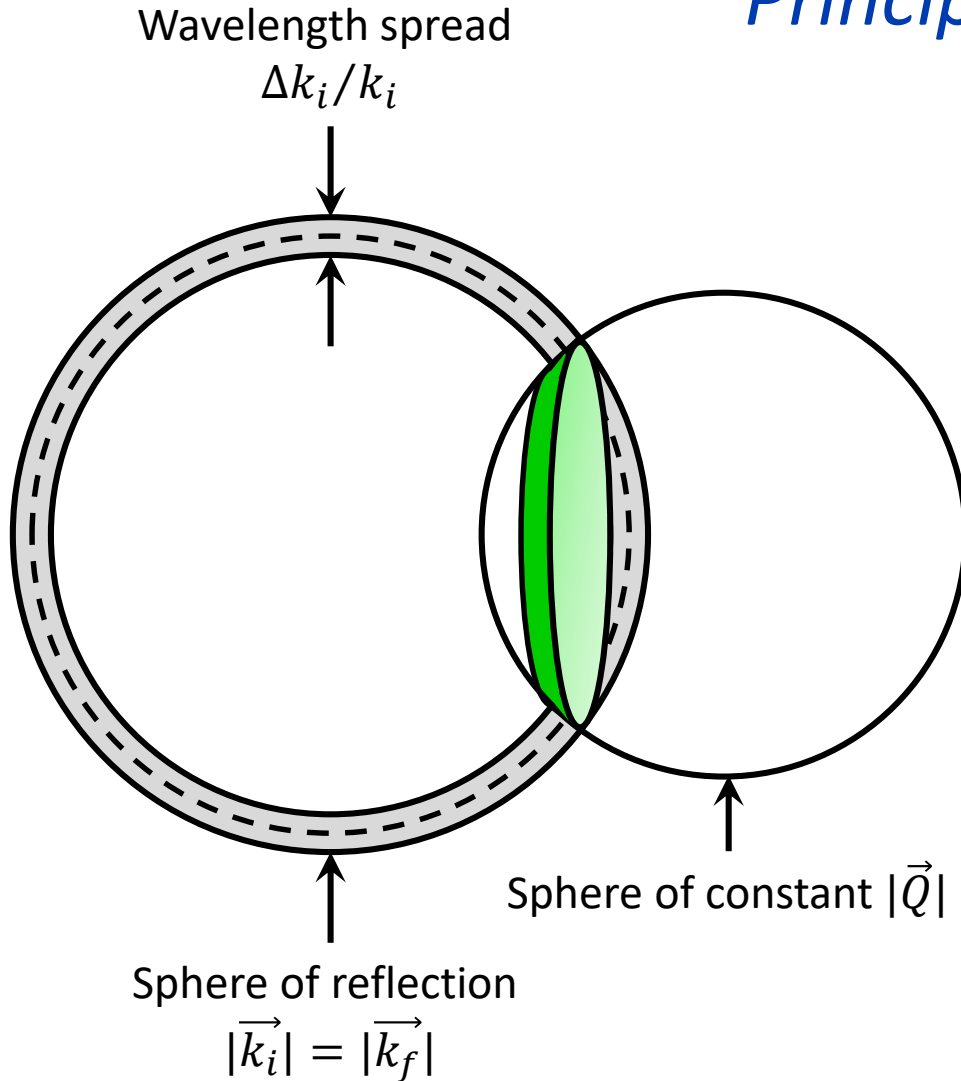

Bragg's law:

$$\theta = \arcsin\left(\frac{\lambda \cdot Q}{4\pi}\right)$$

→ At small angles:

- Large scattered intensity (wavelength spread + Lorentz factor)
- Measurements take place around direct beam: only 'ferromagnetic' components are seen
- No 'real' refinement

Small angle single crystal diffraction

(1) Metastable skyrmion lattice in MnSi

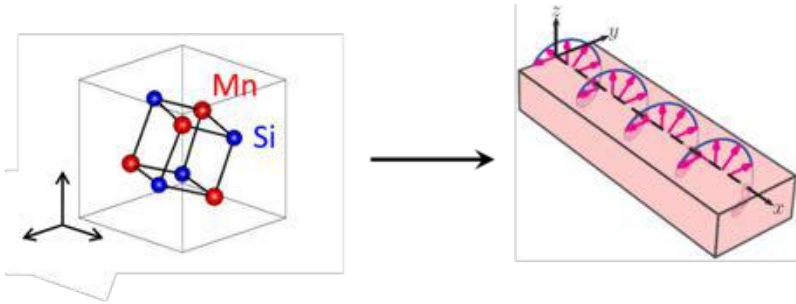

- Crystal structure lacking inversion symmetry \rightarrow Chirality inherited by magnetism (spin-orbit coupling)

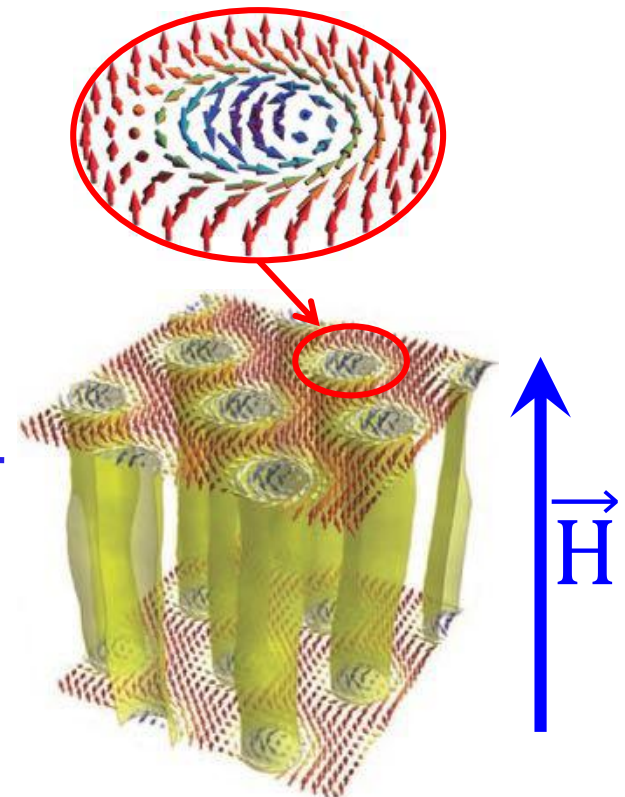
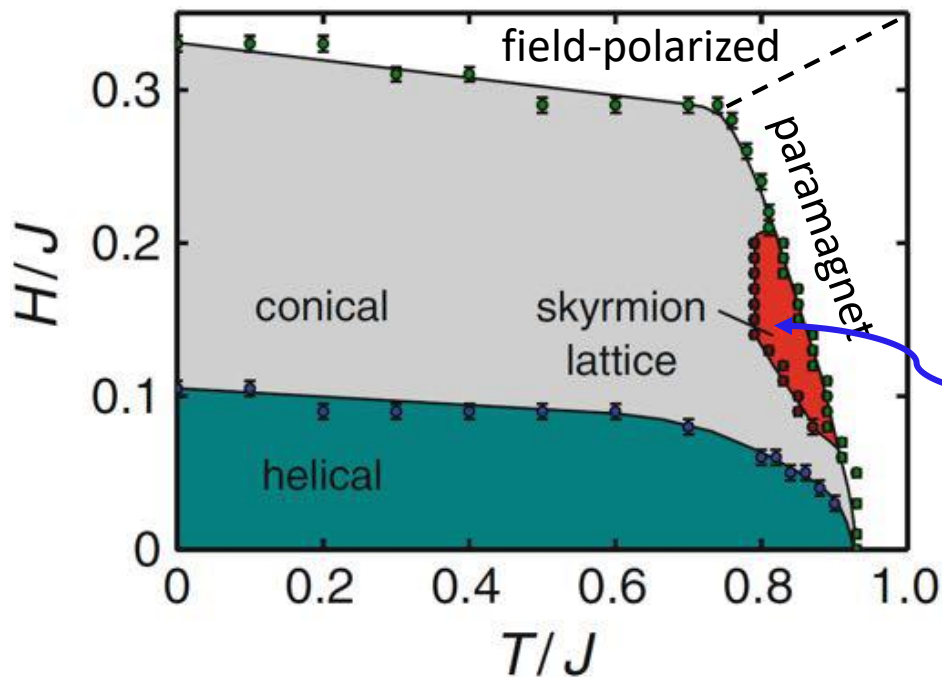

Small angle single crystal diffraction

(1) Metastable skyrmion lattice in MnSi

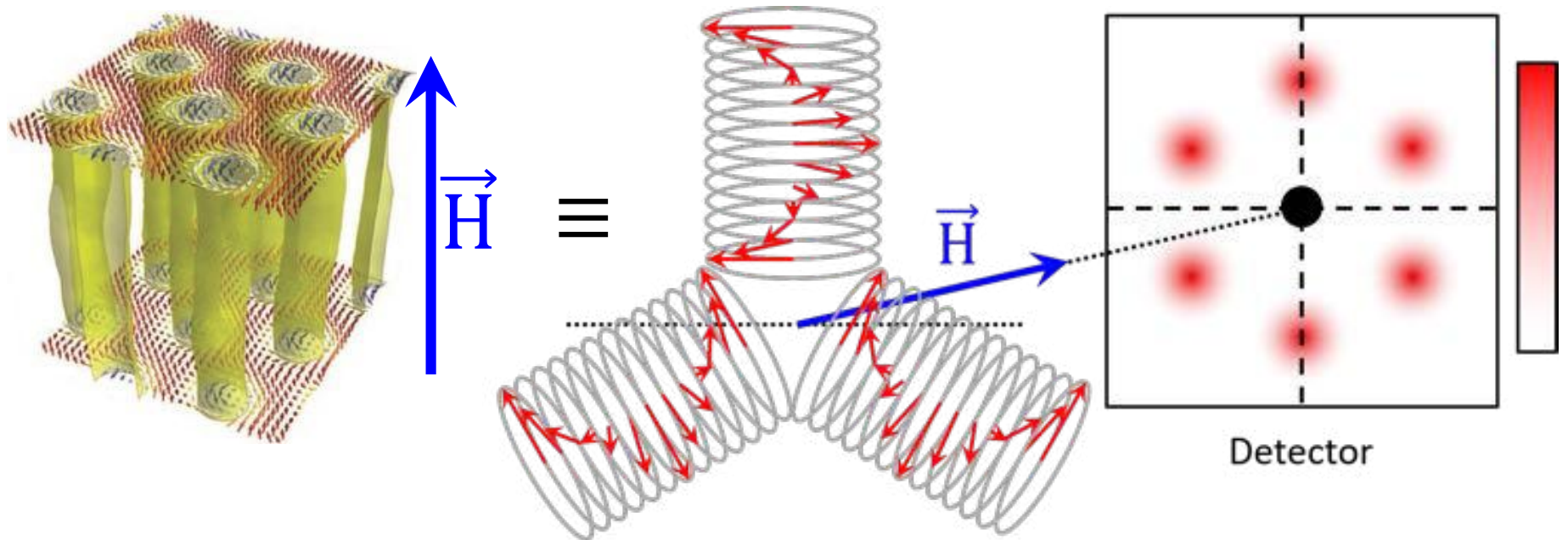

Small angle single crystal diffraction

(1) Metastable skyrmion lattice in MnSi

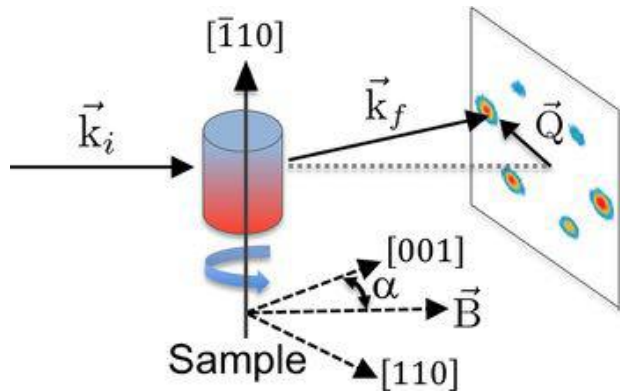

- Stepwise rotation within the applied field
- Irreversible change of skyrmion lattice orientation (depends on magnetic field direction and history)

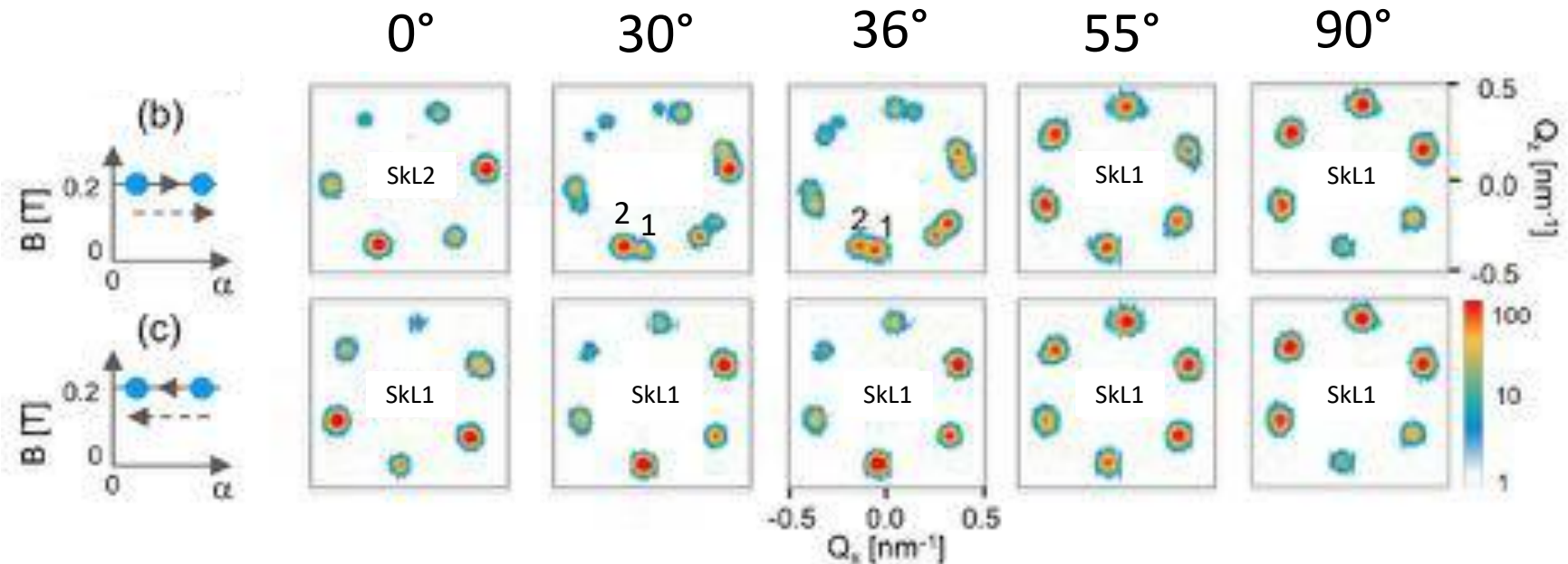

Small angle single crystal diffraction

(1) Metastable skyrmion lattice in MnSi

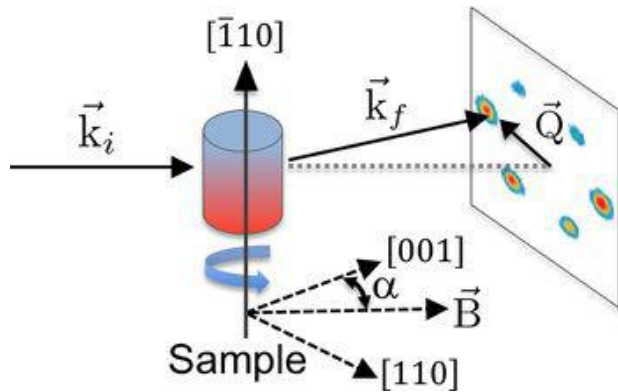

- Quick rotation of 55° within the applied field
- Relaxation of the skyrmion lattice over two characteristic time scales: few s and few minutes

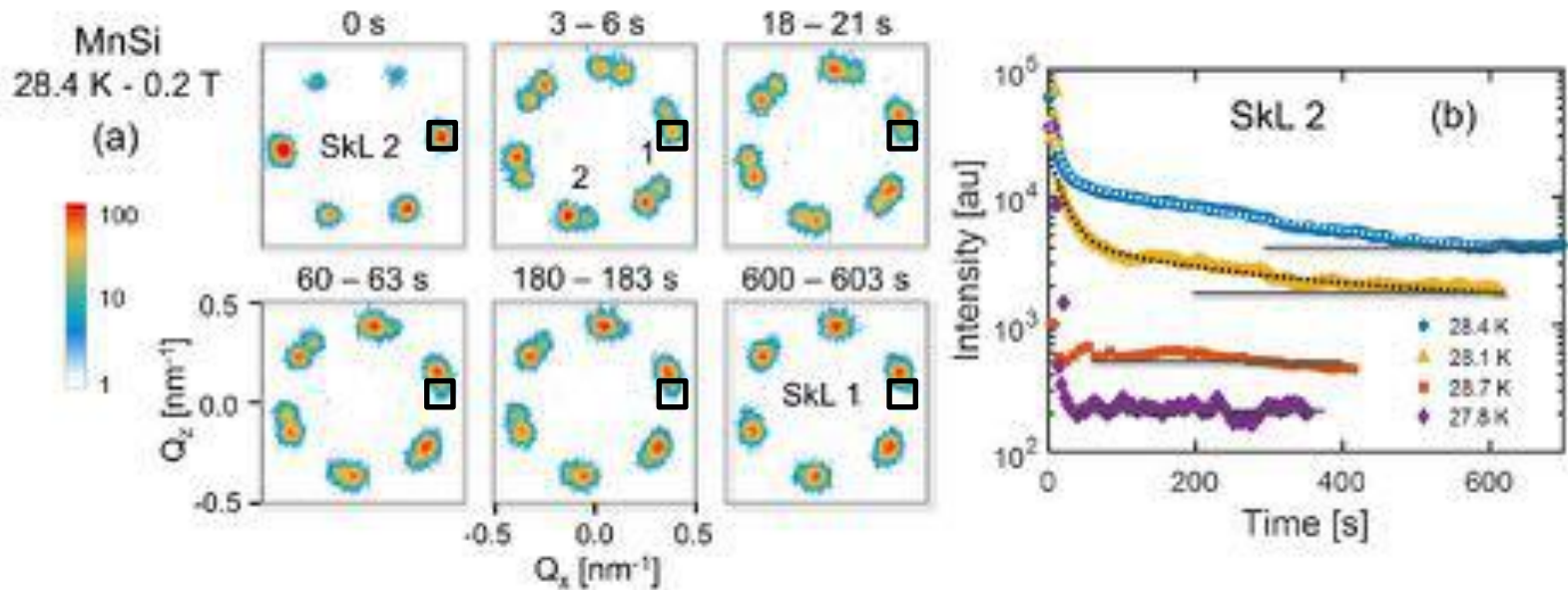

Small-angle powder diffraction

(2) *From short- to long-period helimagnetism in $Mn_{1-x}Rh_xGe$*

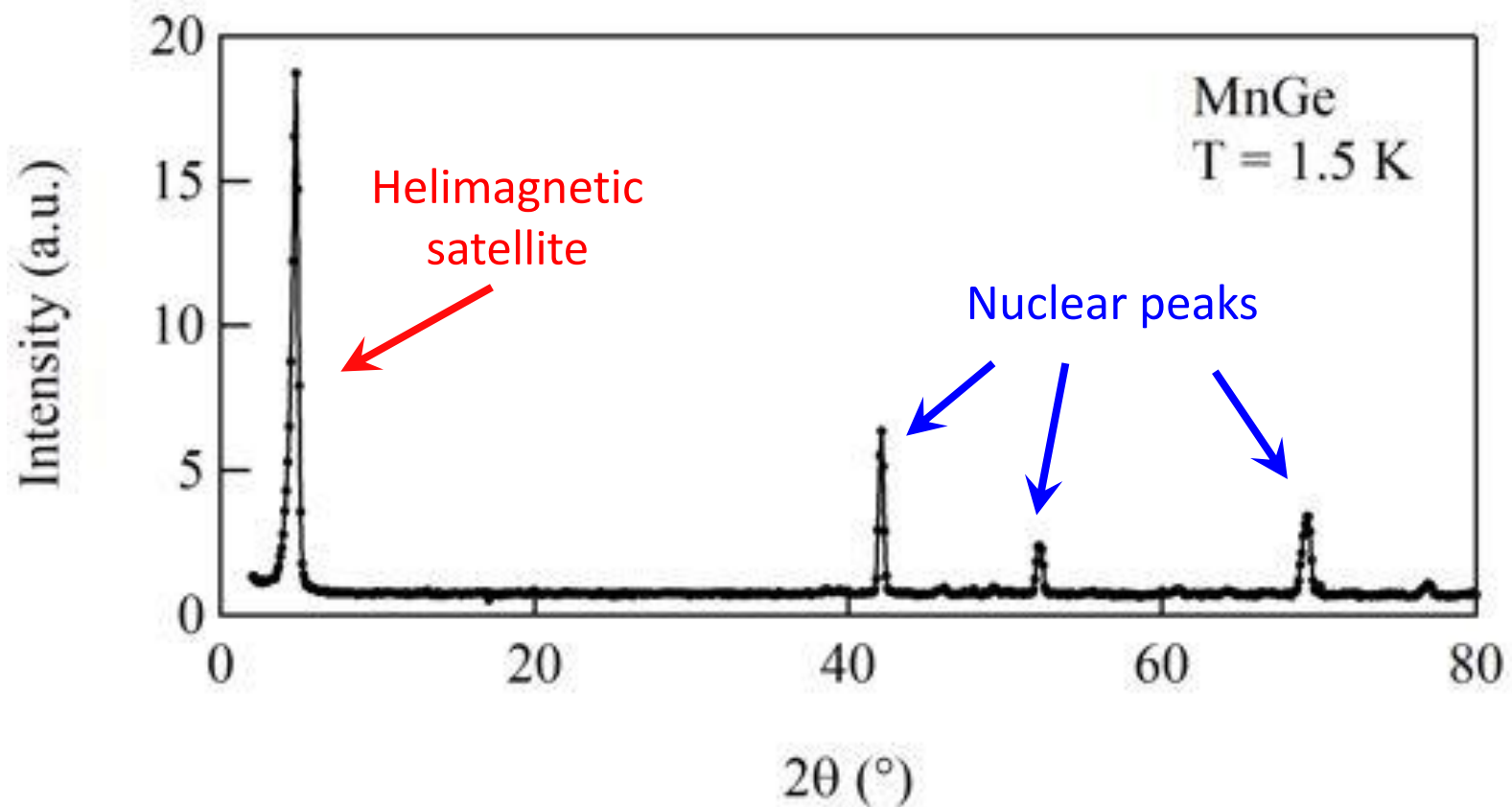

Small-angle powder diffraction

(2) From short- to long-period helimagnetism in $Mn_{1-x}Rh_xGe$

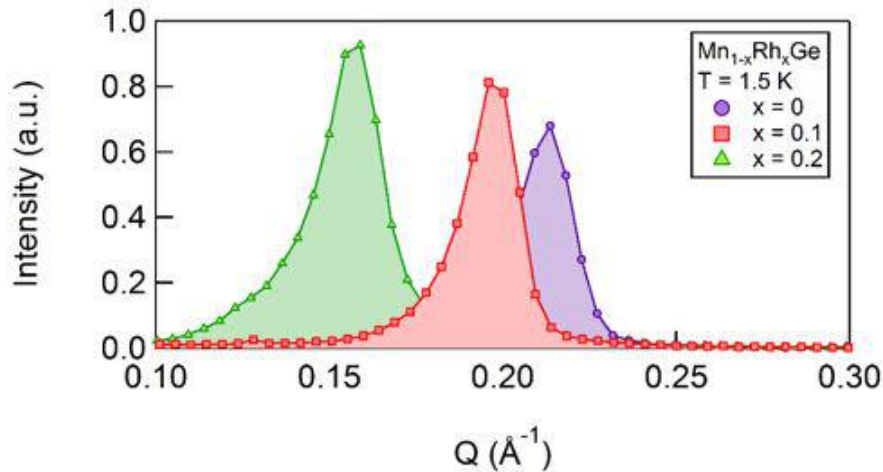

Powder diffraction (G4.1, LLB)

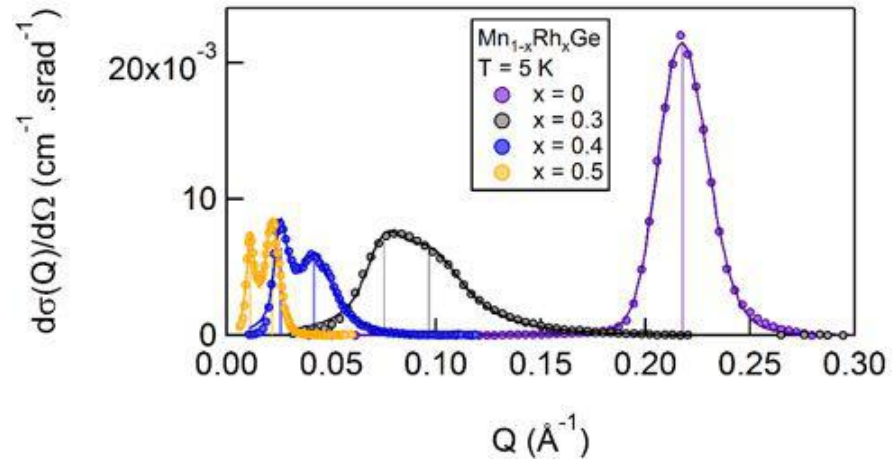

Small angle scattering (PA20, LLB)

Magnetic diffraction peak parameters

- Position $Q_H \rightarrow$ magnetic structure periodicity $\lambda_H = 2\pi/Q_H$
- Integrated intensity $I \rightarrow$ magnetic moment value $m = \sqrt{I}$
- Width $\kappa_H \rightarrow$ magnetic structure coherence length $\xi_H = 1/\kappa_H$

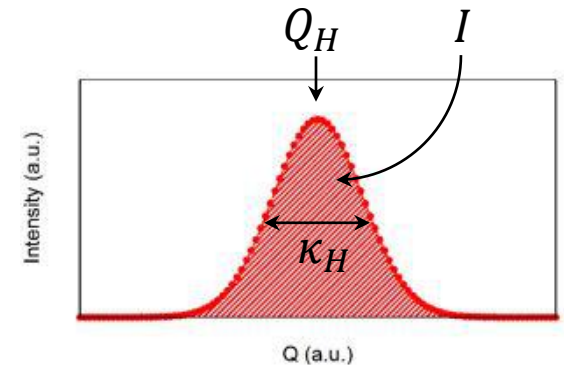

Small-angle powder diffraction

(2) From short- to long-period helimagnetism in $Mn_{1-x}Rh_xGe$

- Magnetic period:

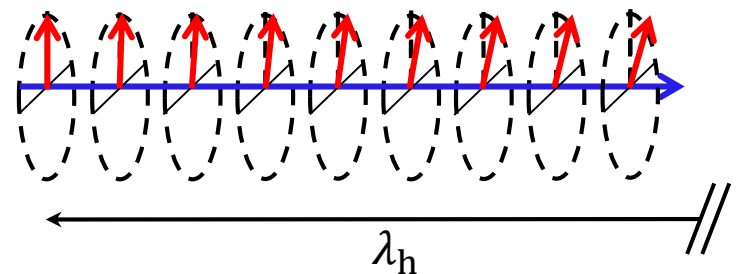
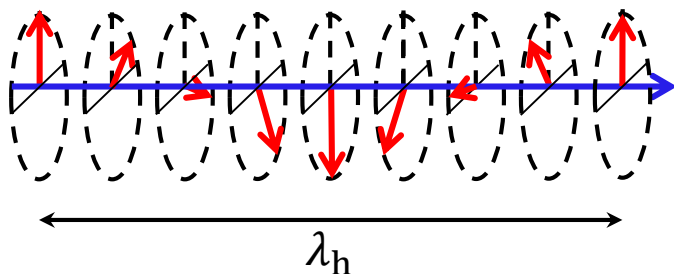
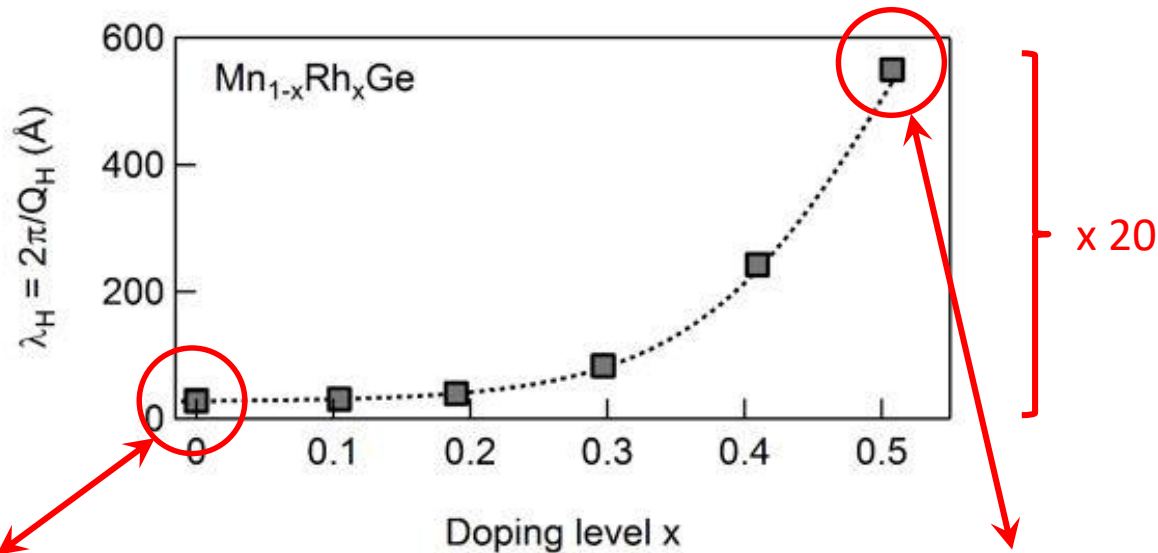

Small-angle powder diffraction

(2) From short- to long-period helimagnetism in $Mn_{1-x}Rh_xGe$

- Ordered moment:

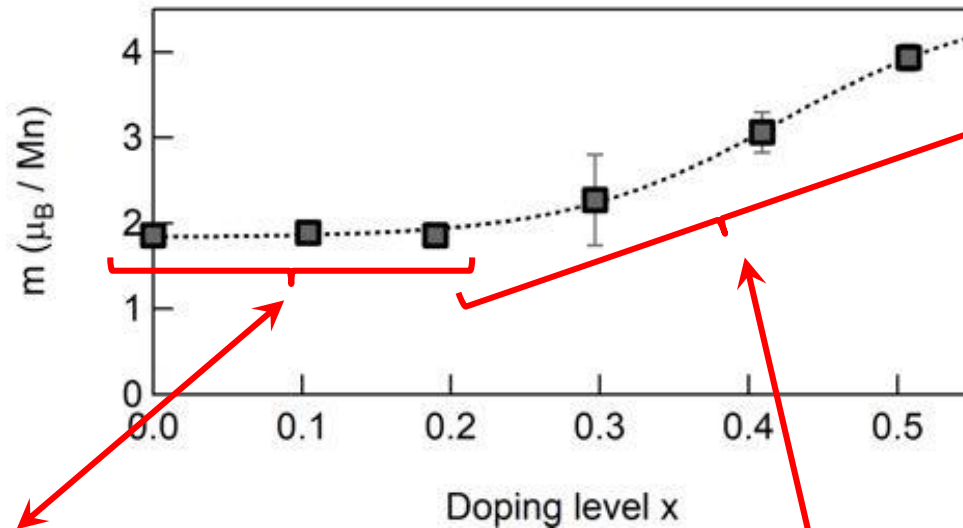

Powder diffraction
(refined)

SANS (rescaled)

Small-angle powder diffraction

(2) From short- to long-period helimagnetism in $Mn_{1-x}Rh_xGe$

- Correlation length (resolution deconvolved):

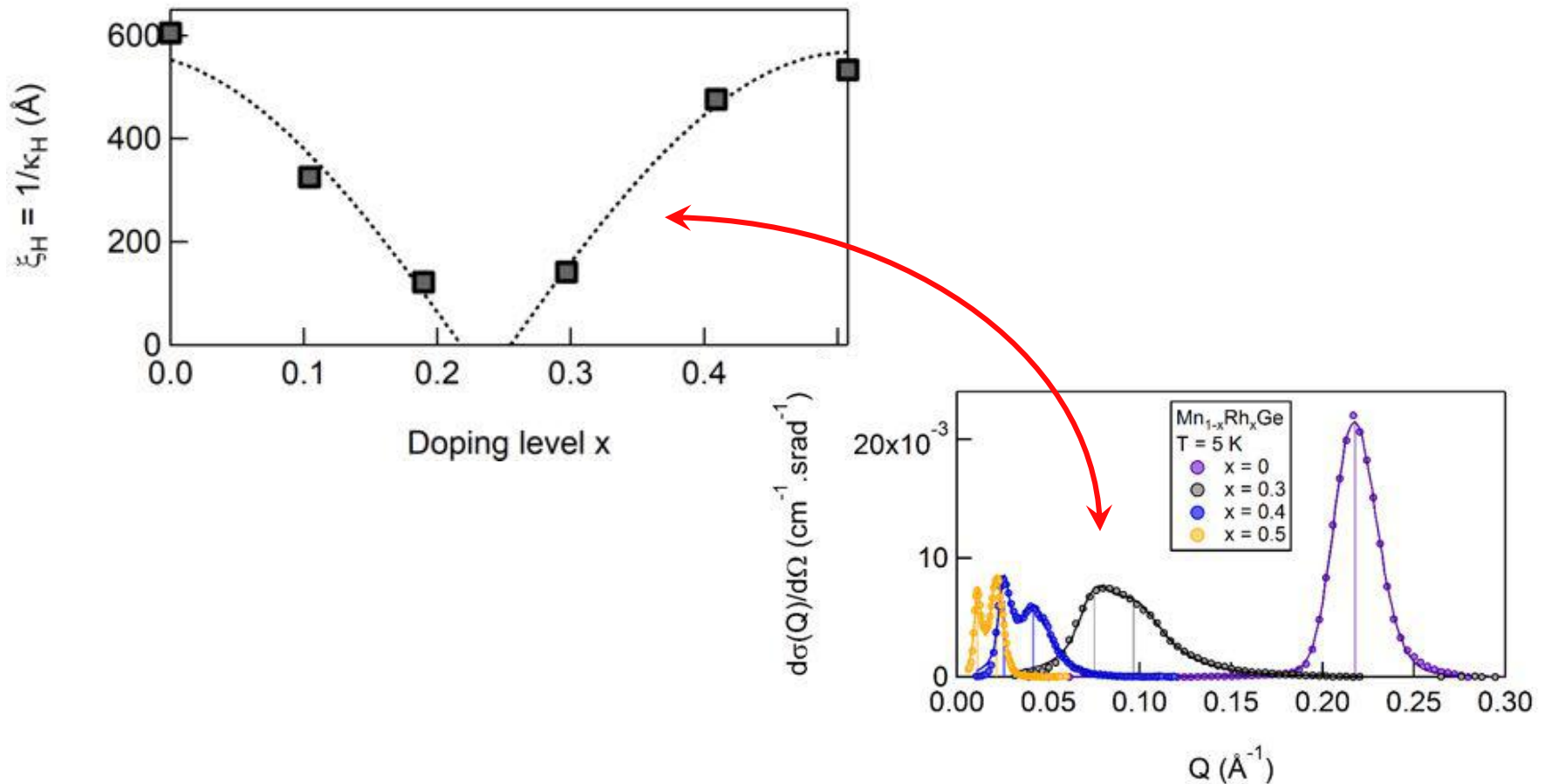

SANS for 'hard condensed matter'

Content of the talk

1. Magnetic (small angle) neutron scattering
2. Small angle diffraction
- 3. Magnetic form factor measurement**
4. Inelastic scattering
5. Advanced SANS techniques

Magnetic form factor measurement

(1) Magnetization distribution in spin-crossover nanoparticles

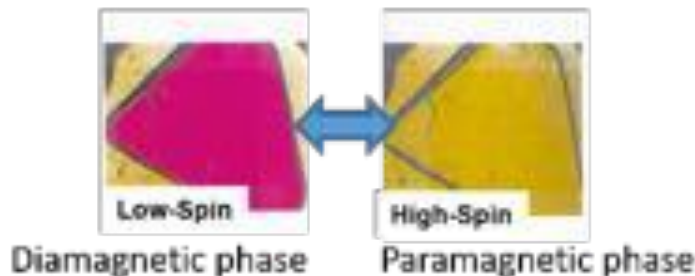
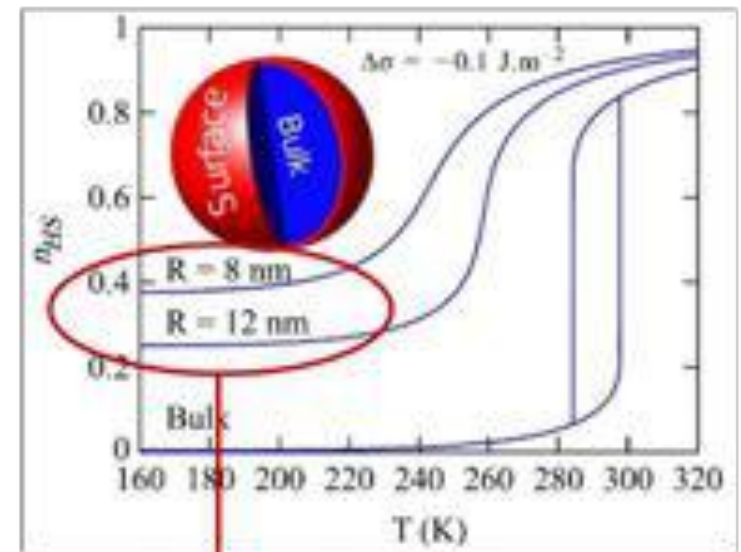
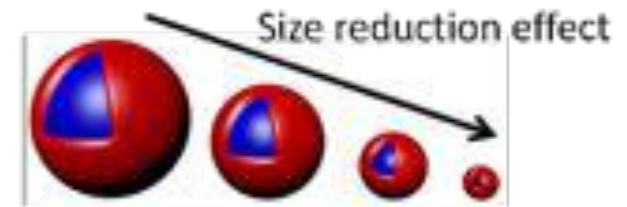
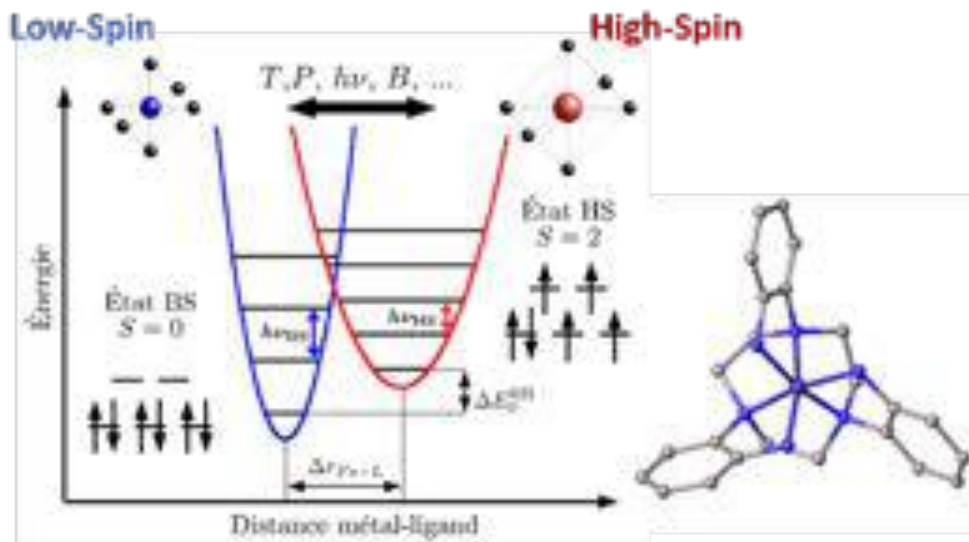

In nanoparticles : existence of a residual HS fraction at low temperature (incomplete transition)

➤ Where is localized this residual fraction? Surface? Homogeneous distribution?

Magnetic form factor measurement

(1) Magnetization distribution in spin-crossover nanoparticles

Spatial localization of the residual (paramagnetic) HS fraction within the nanoparticles

SANS measurements performed at 5 K and 5 T

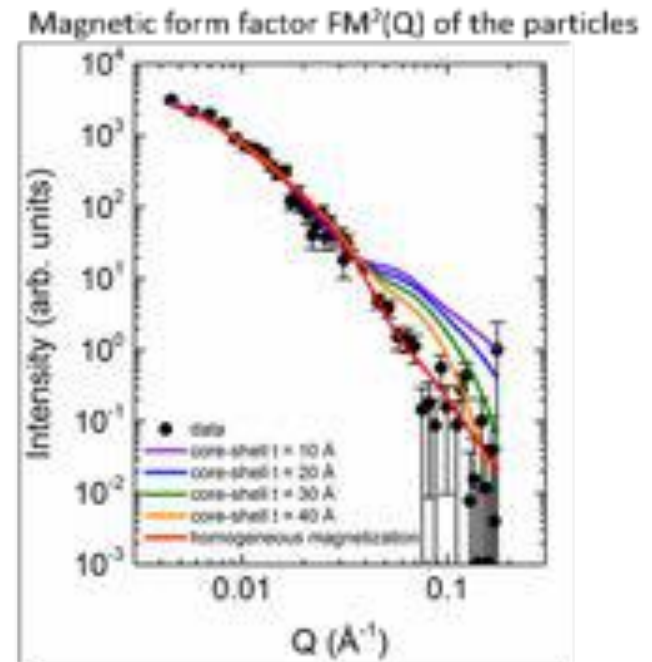
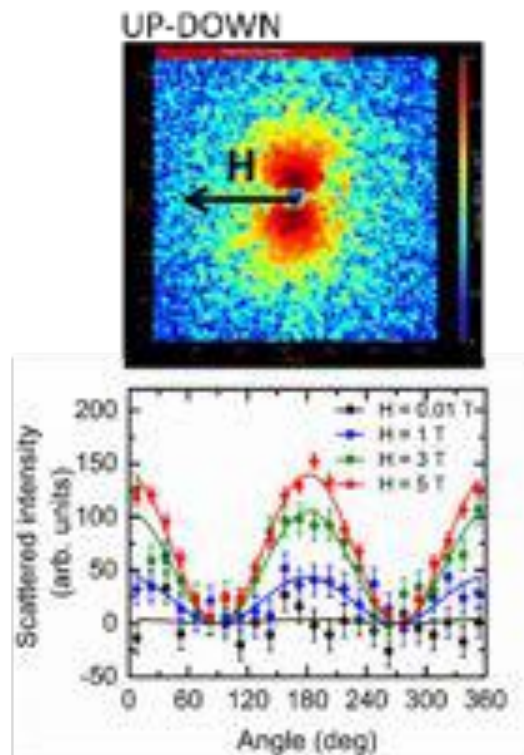
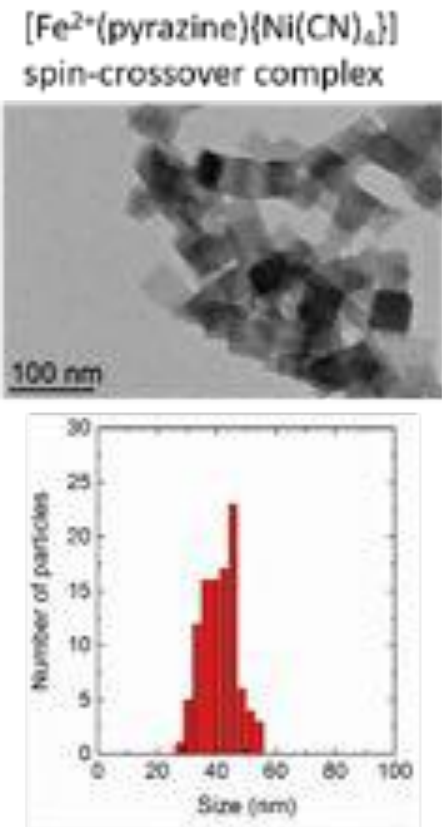

SANS data indicate that the residual HS fraction is uniformly distributed within the particles, rather than concentrated at the extreme surface

Magnetic form factor measurement

(2) Spin vortices in a reentrant spin glass

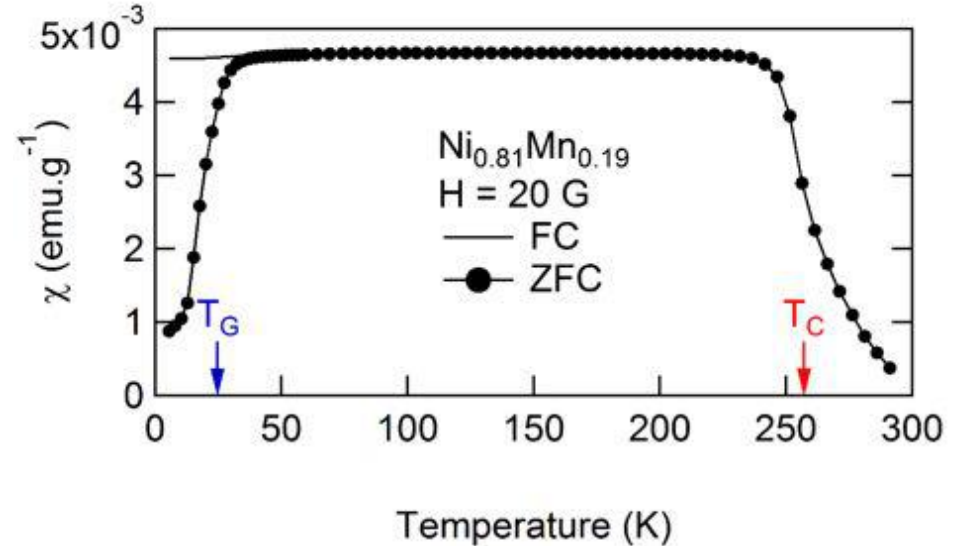
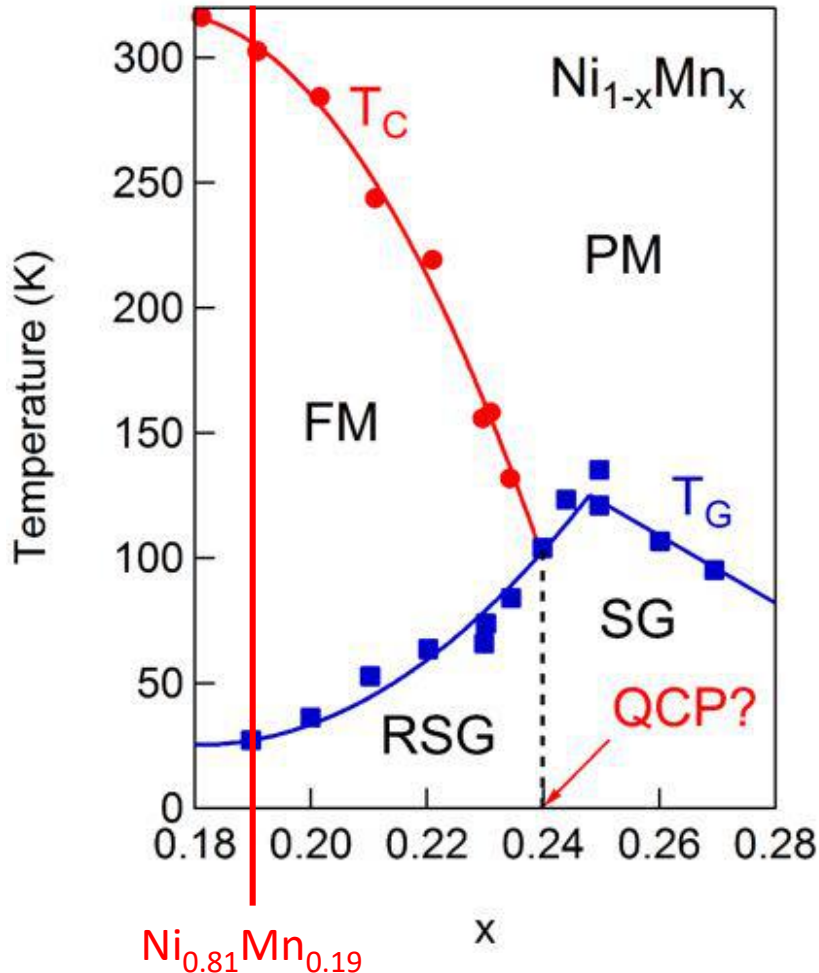

- **Nearest neighbor interaction frustration:**
 - Ni-Ni & Ni-Mn: ferromagnetic (FM)
 - Mn-Mn: antiferromagnetic (AFM)
- **Generic phase diagram:**
 - $T_C \rightarrow$ FM ordering
 - $T_G \rightarrow$ spin-glass transition, onset of FC/ZFC irreversibilities

Magnetic form factor measurement

(2) Spin vortices in a reentrant spin glass

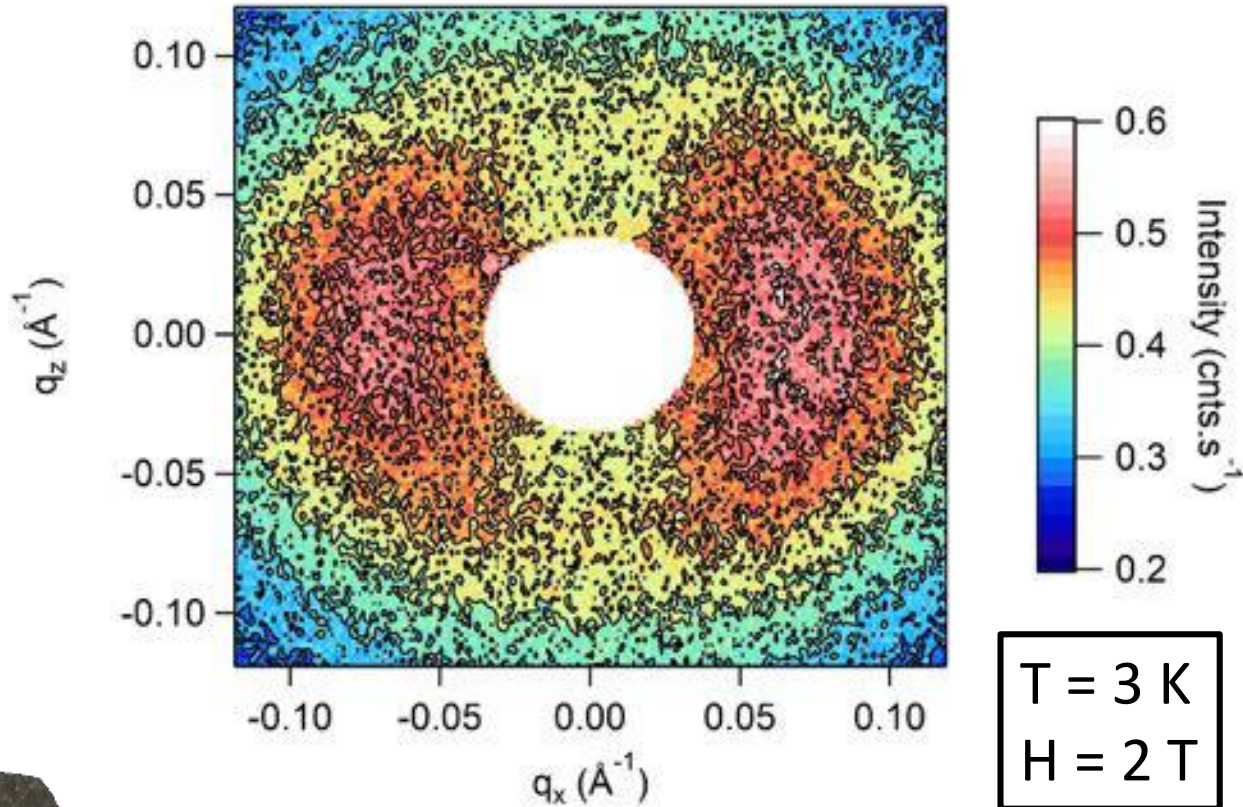

Magnetic form factor measurement

(2) Spin vortices in a reentrant spin glass

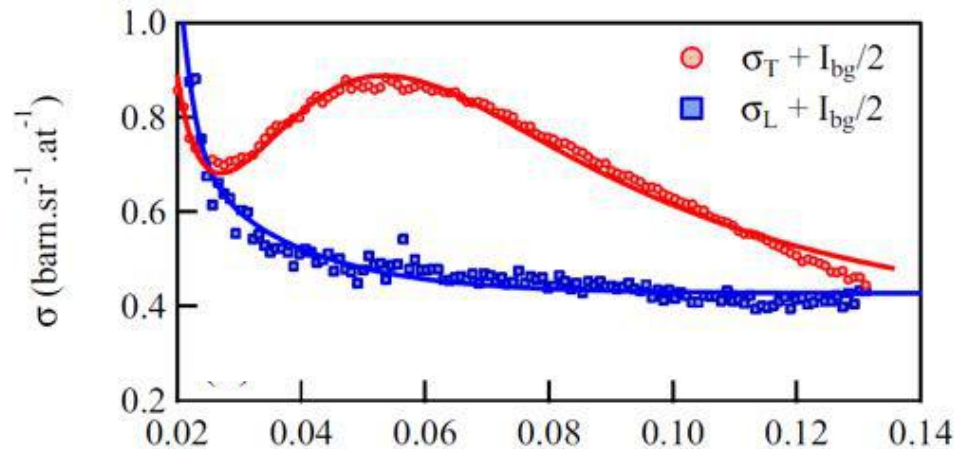
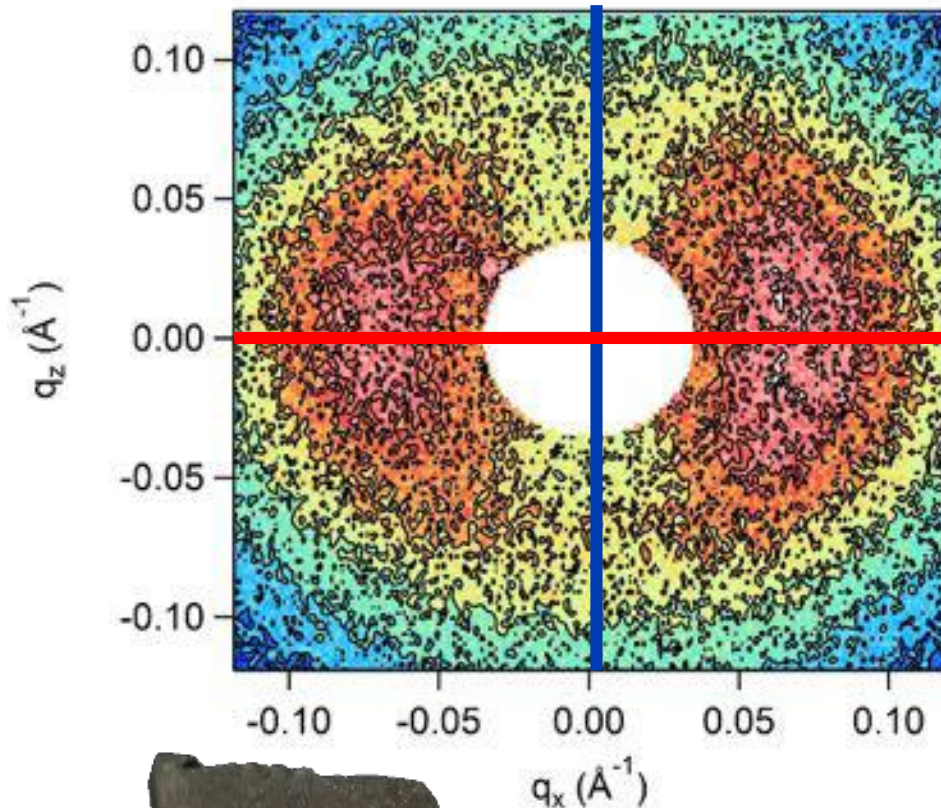

Magnetic form factor measurement

(2) Spin vortices in a reentrant spin glass

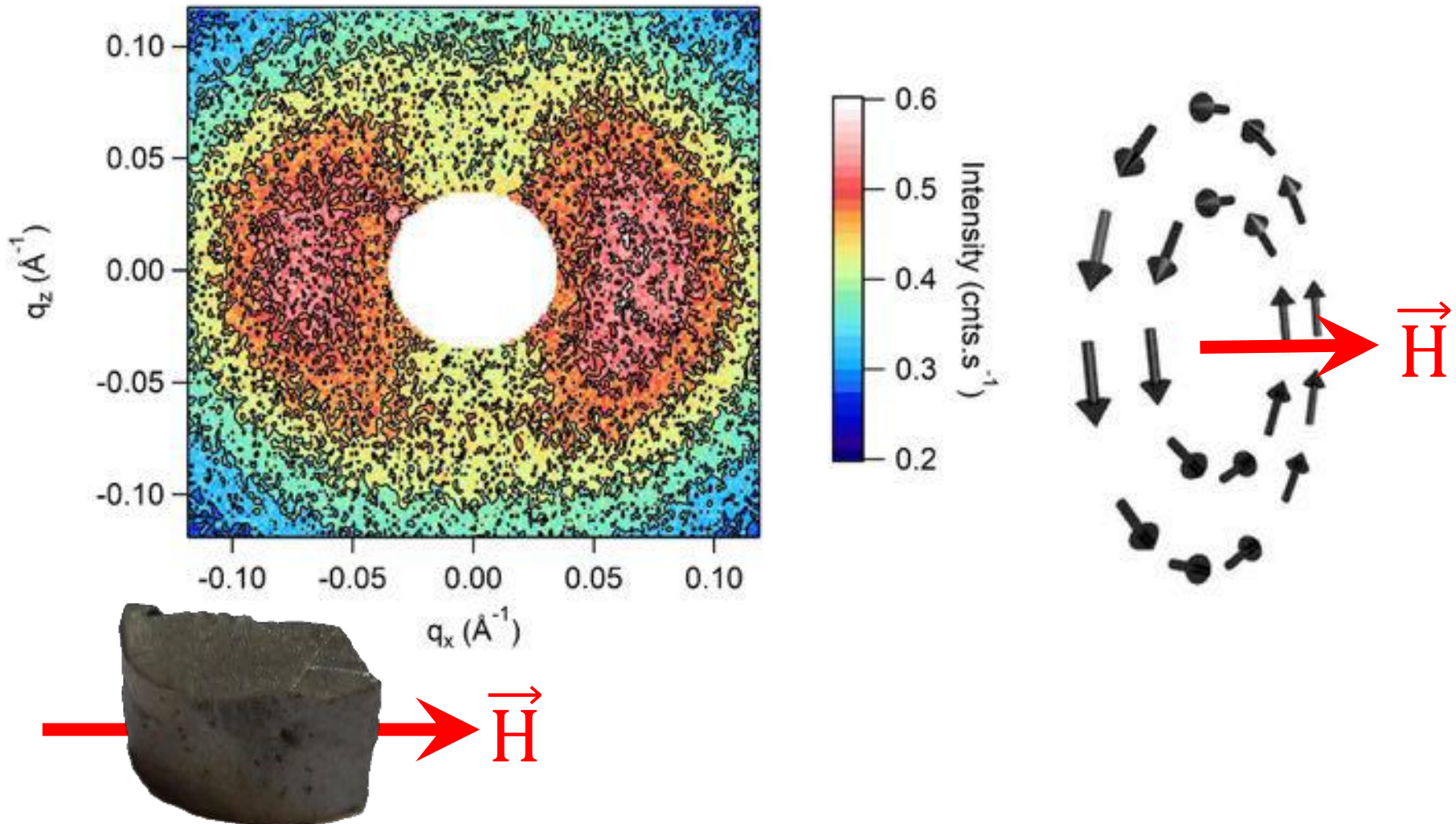

Magnetic form factor measurement

(2) Spin vortices in a reentrant spin glass

Integrated intensity vs. H
(2 different spectrometers!)

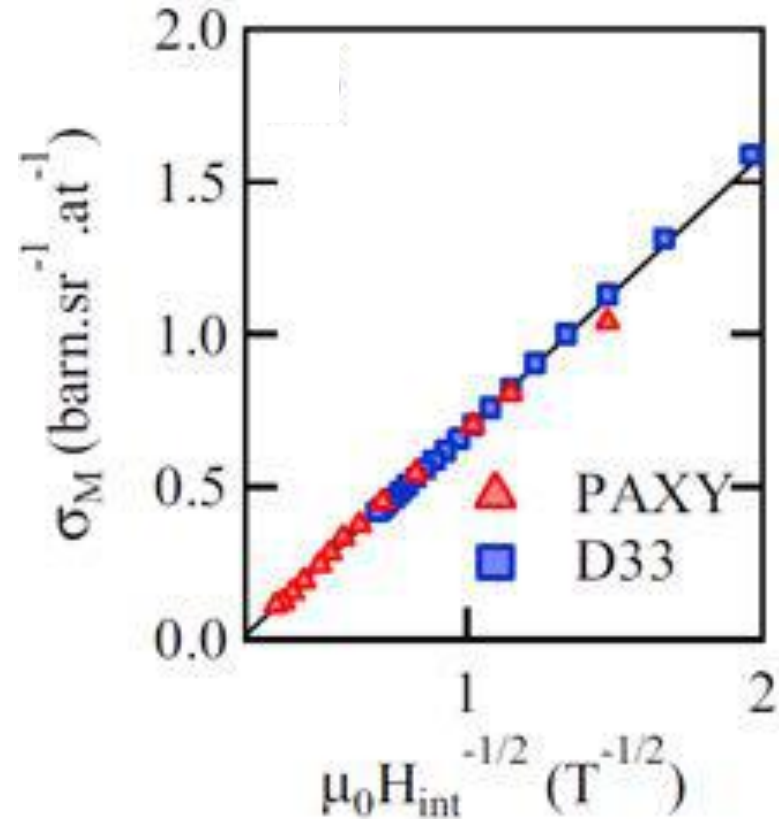
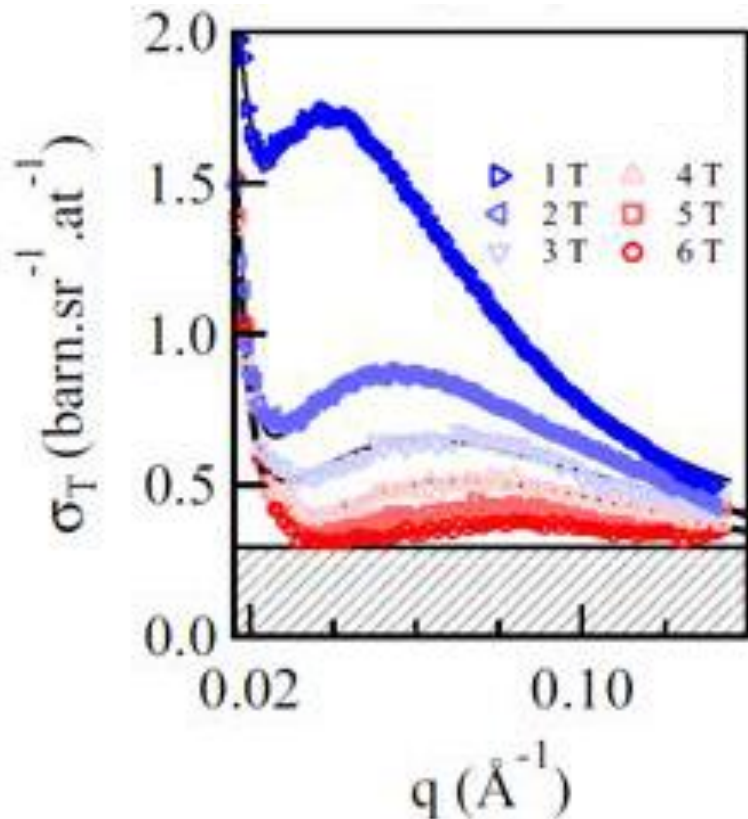

Magnetic form factor measurement

(2) Spin vortices in a reentrant spin glass

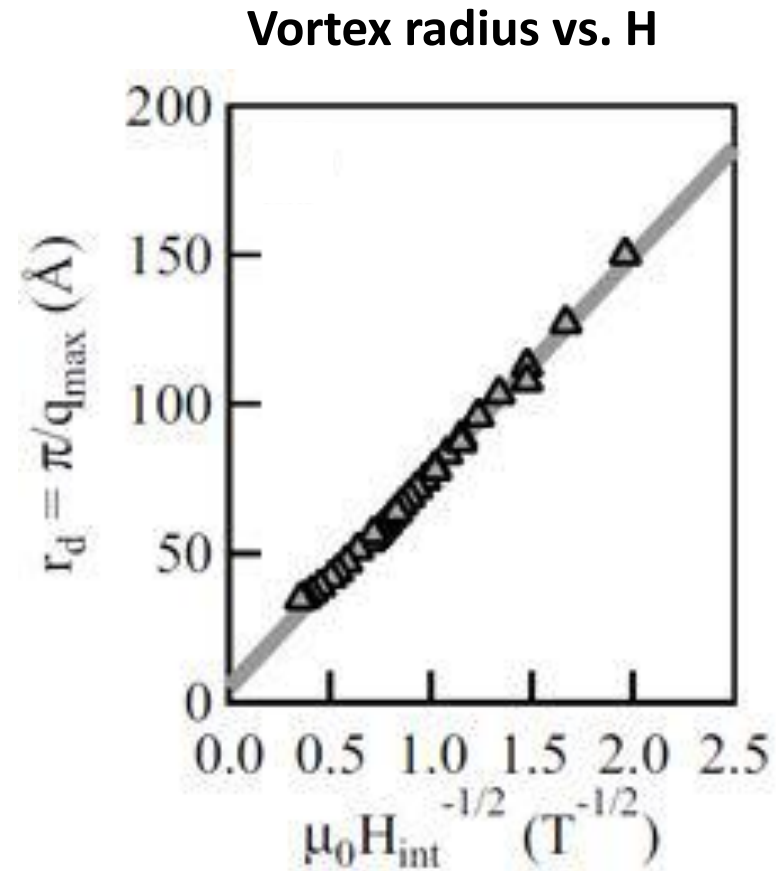
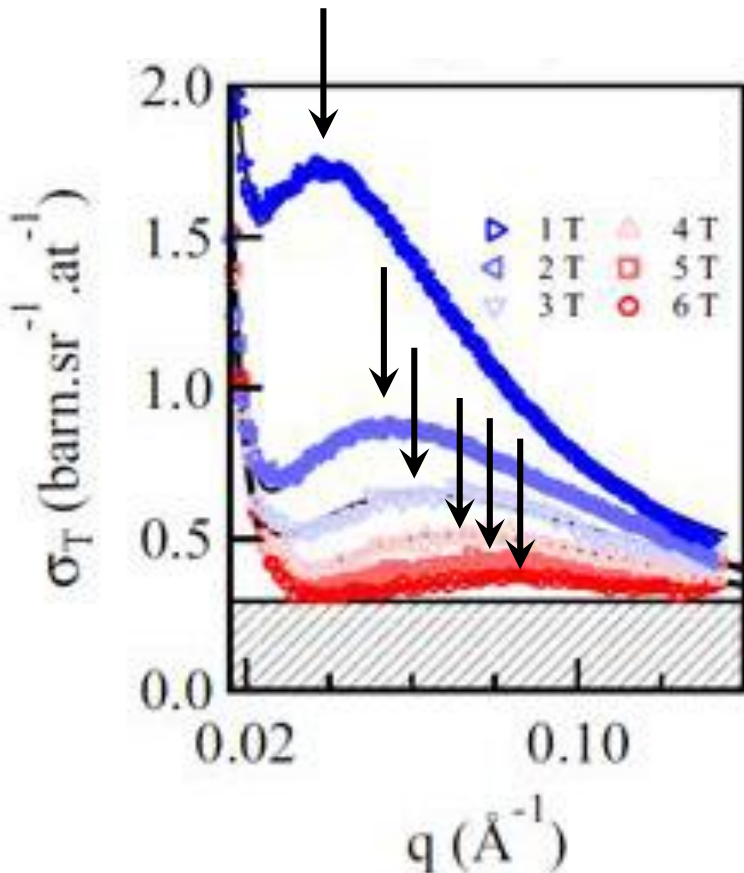

Magnetic form factor measurement

(2) Spin vortices in a reentrant spin glass

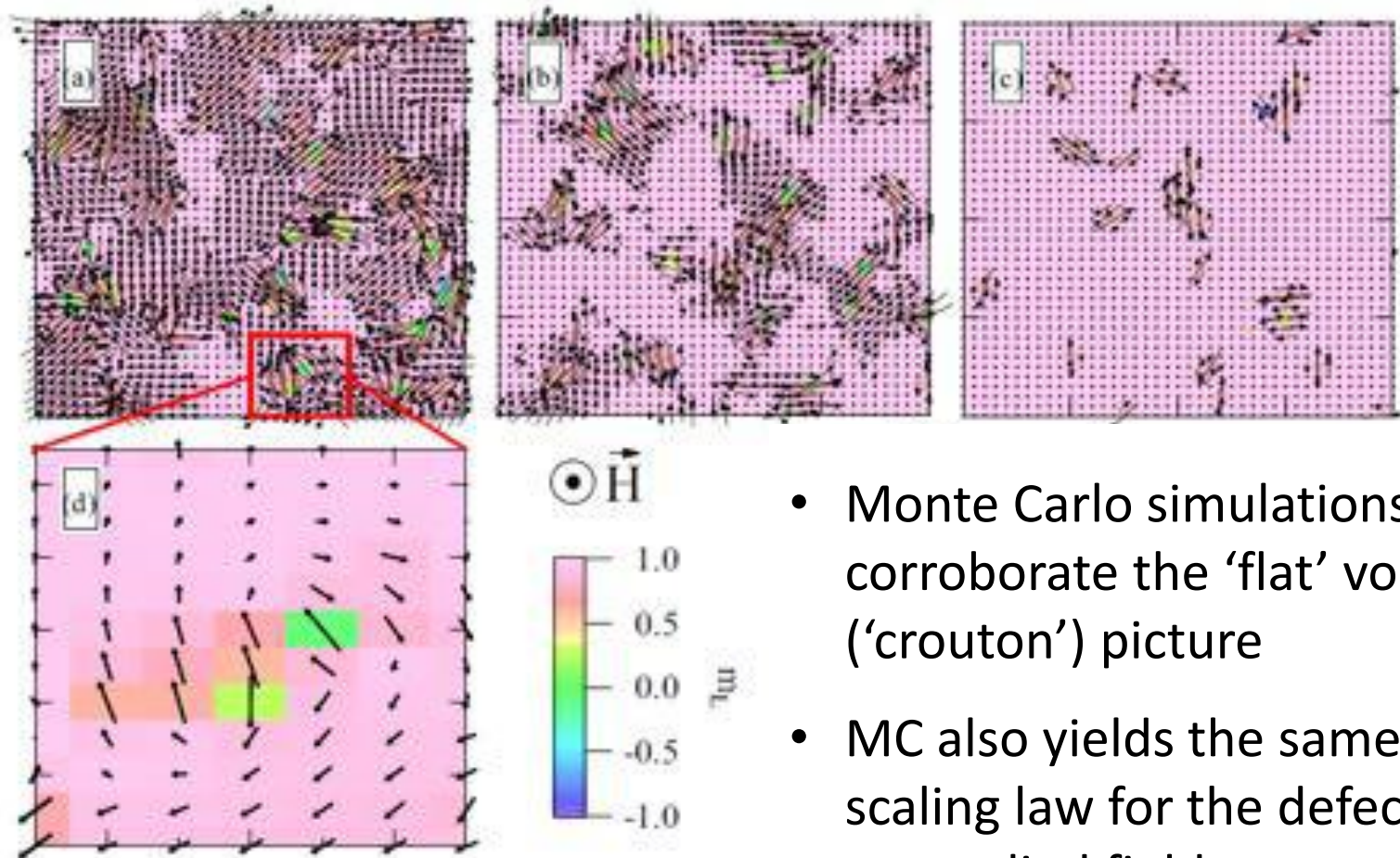

- Monte Carlo simulations corroborate the ‘flat’ vortex (‘crouton’) picture
- MC also yields the same scaling law for the defect size vs. applied field

SANS for 'hard condensed matter'

Content of the talk

1. Magnetic (small angle) neutron scattering
2. Small angle diffraction
3. Magnetic form factor measurement
- 4. Inelastic scattering**
5. Advanced SANS techniques

Inelastic scattering

Measurement of spin wave stiffness

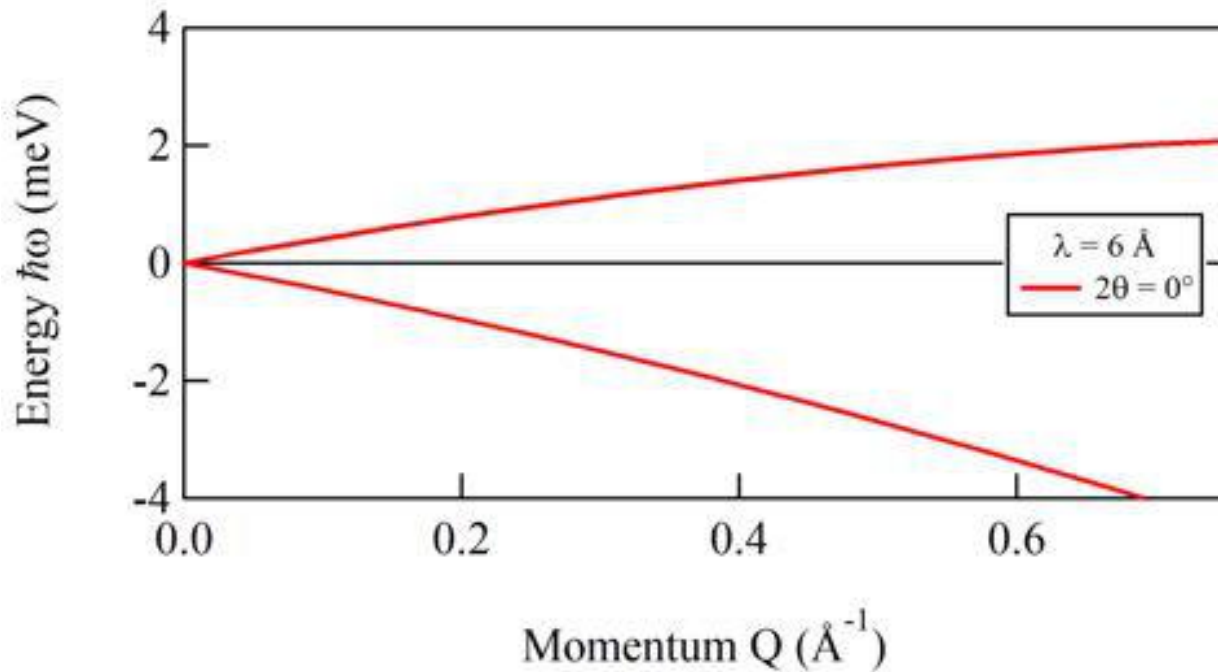
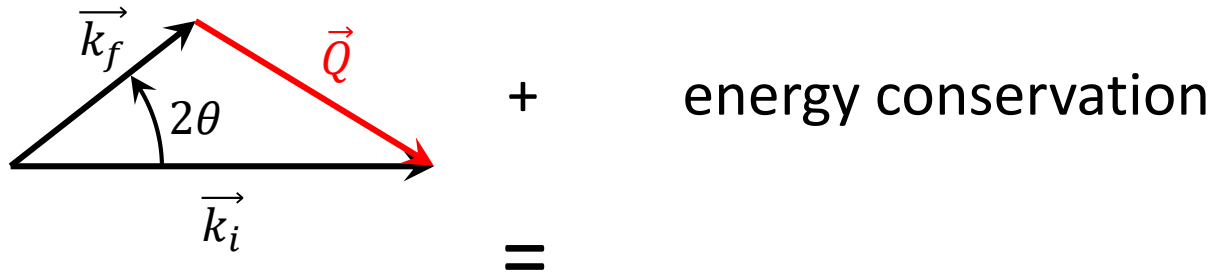

Inelastic scattering

Measurement of spin wave stiffness

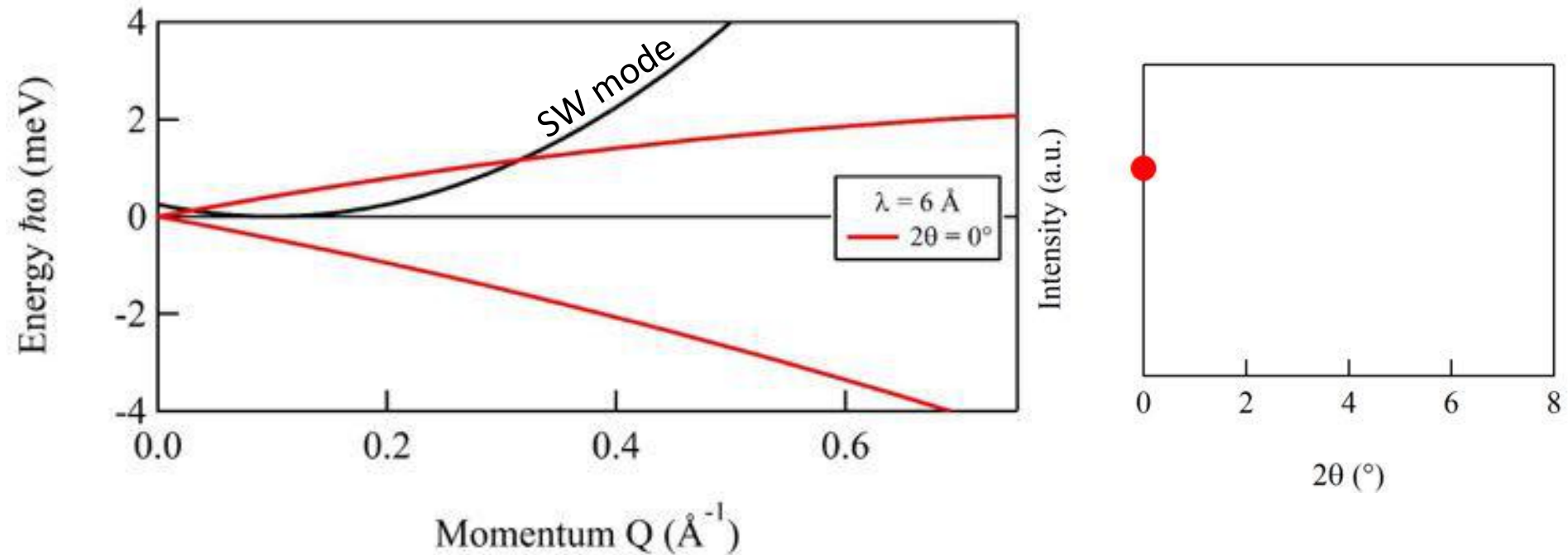
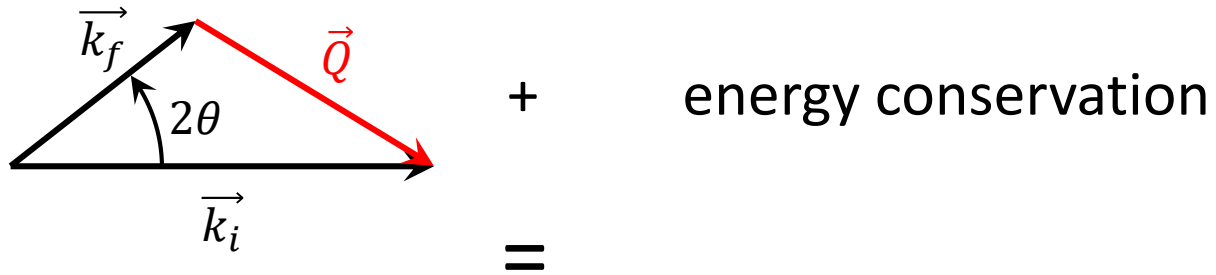

Inelastic scattering

Measurement of spin wave stiffness

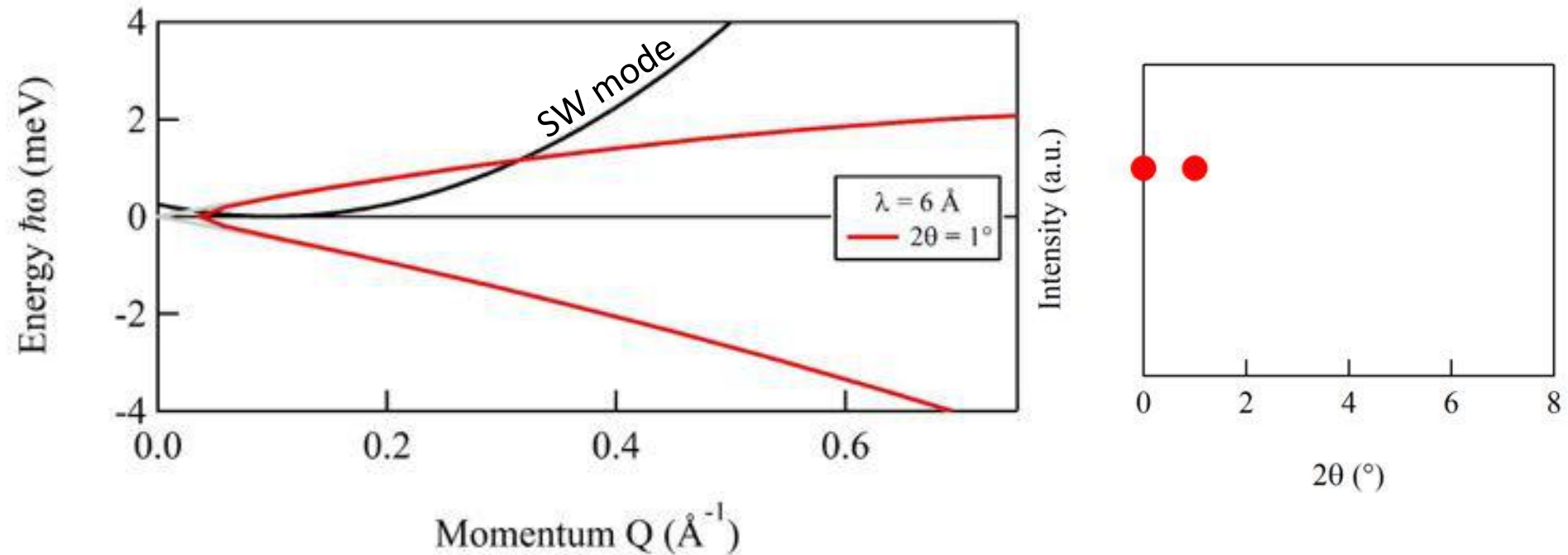
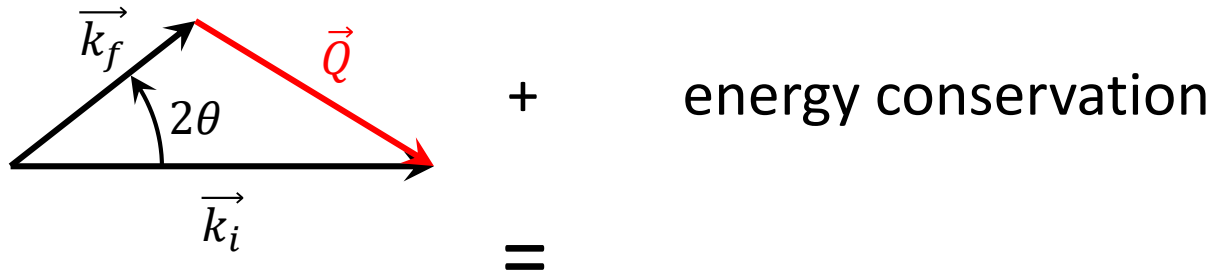

Inelastic scattering

Measurement of spin wave stiffness

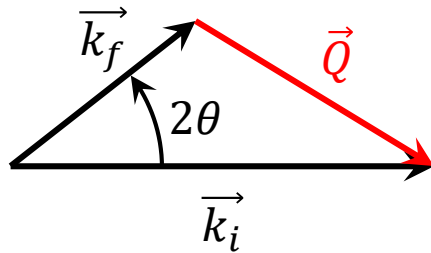

+

energy conservation

=

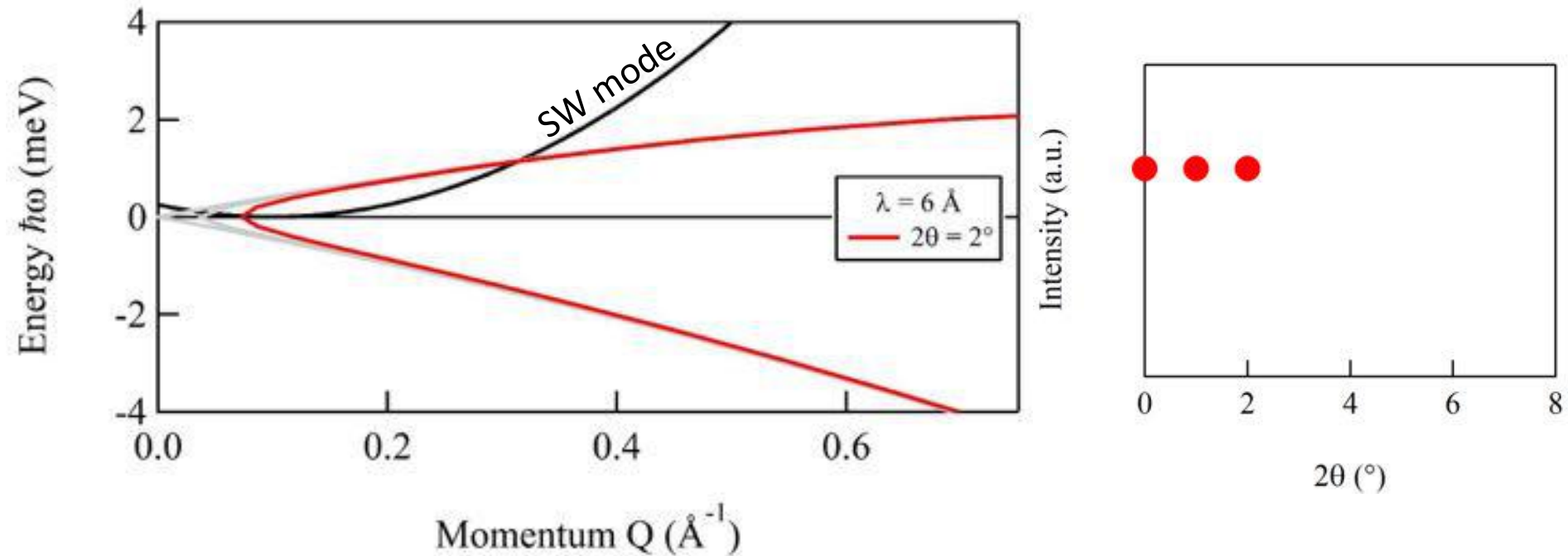

Inelastic scattering

Measurement of spin wave stiffness

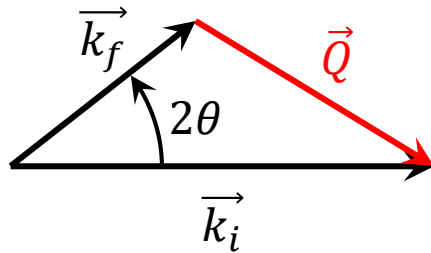

+

energy conservation

=

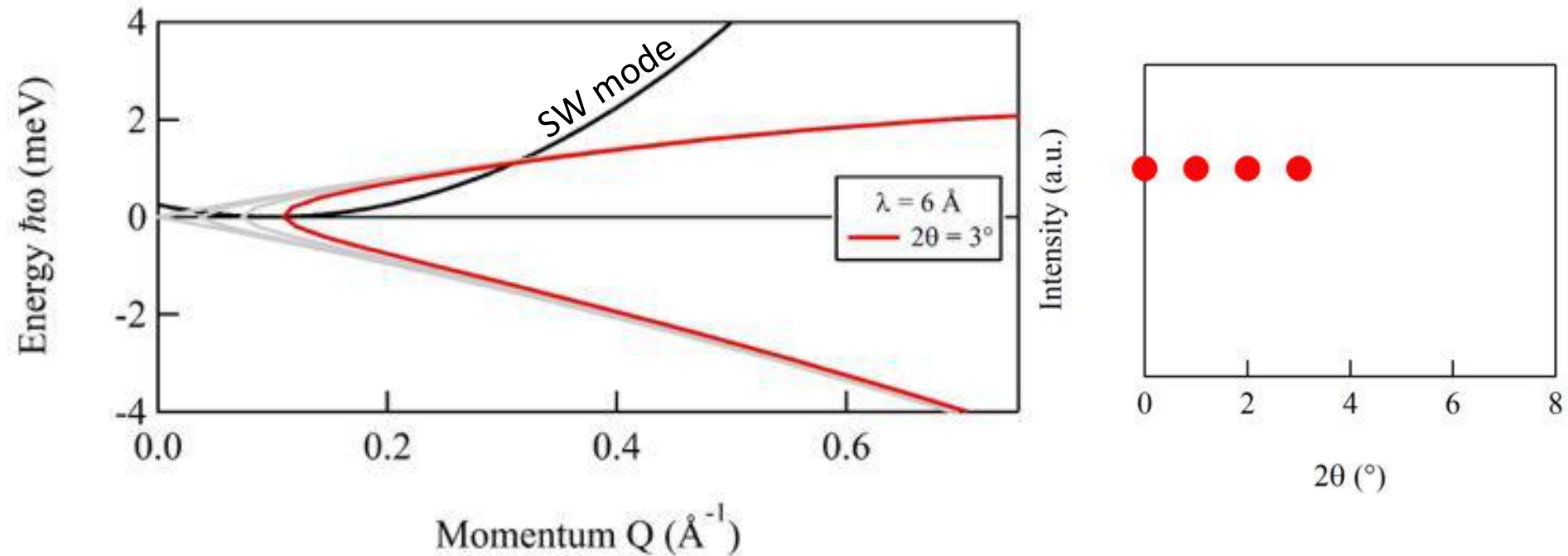

Inelastic scattering

Measurement of spin wave stiffness

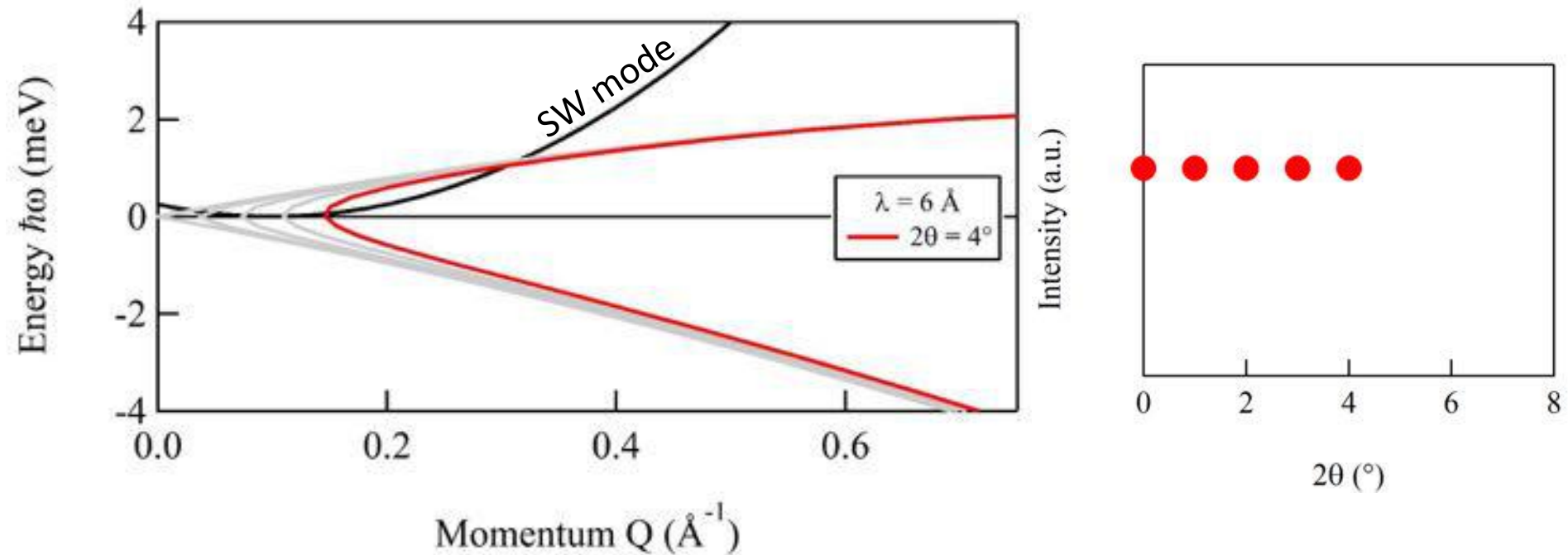
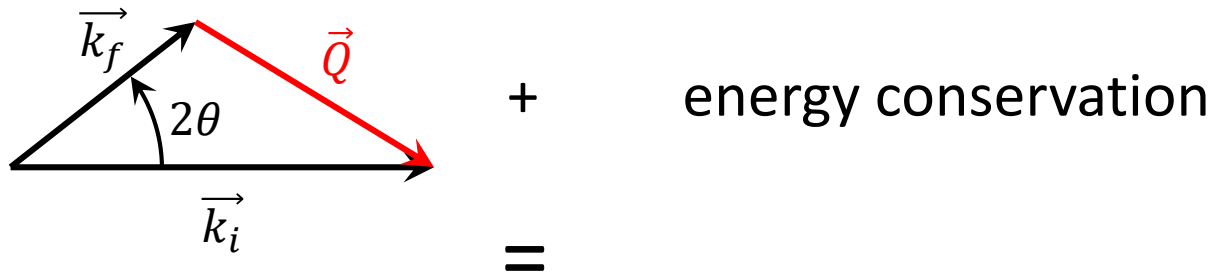

Inelastic scattering

Measurement of spin wave stiffness

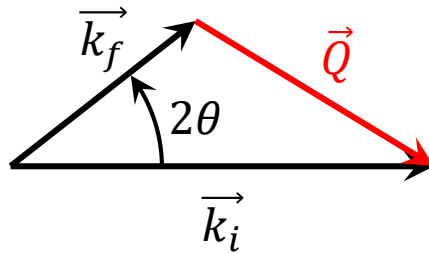

+

energy conservation

=

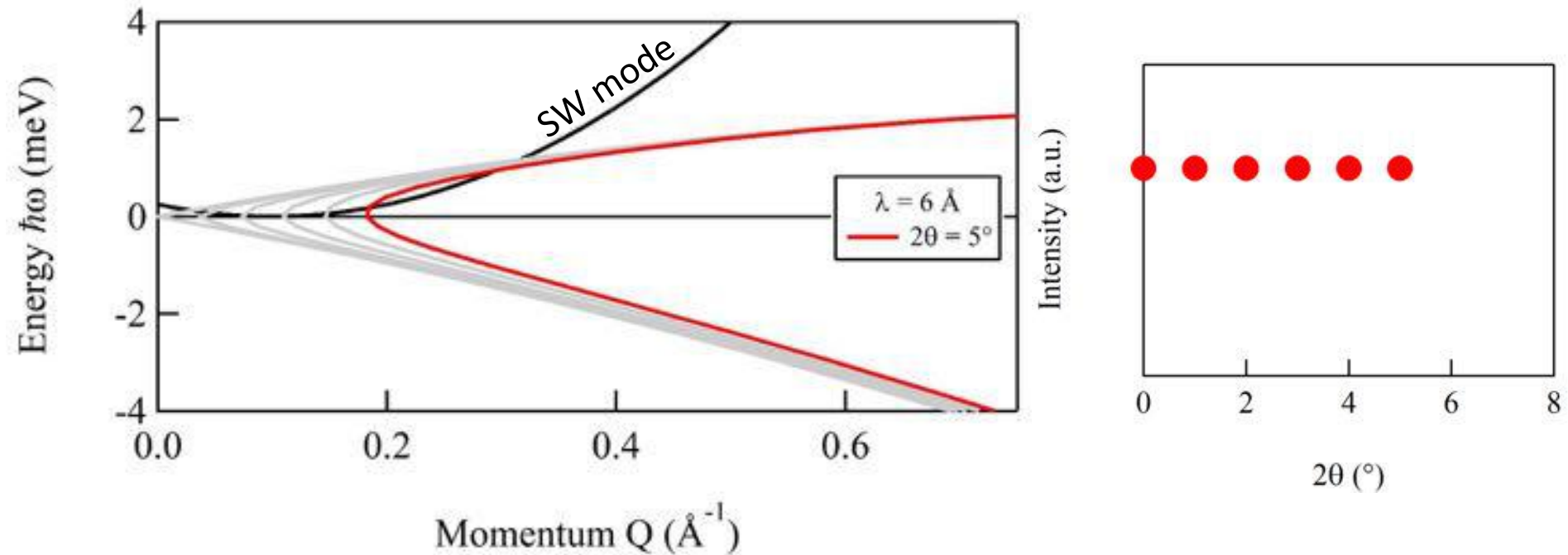

Inelastic scattering

Measurement of spin wave stiffness

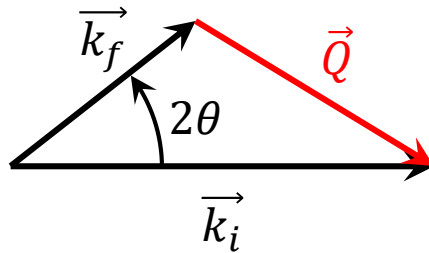

+

energy conservation

=

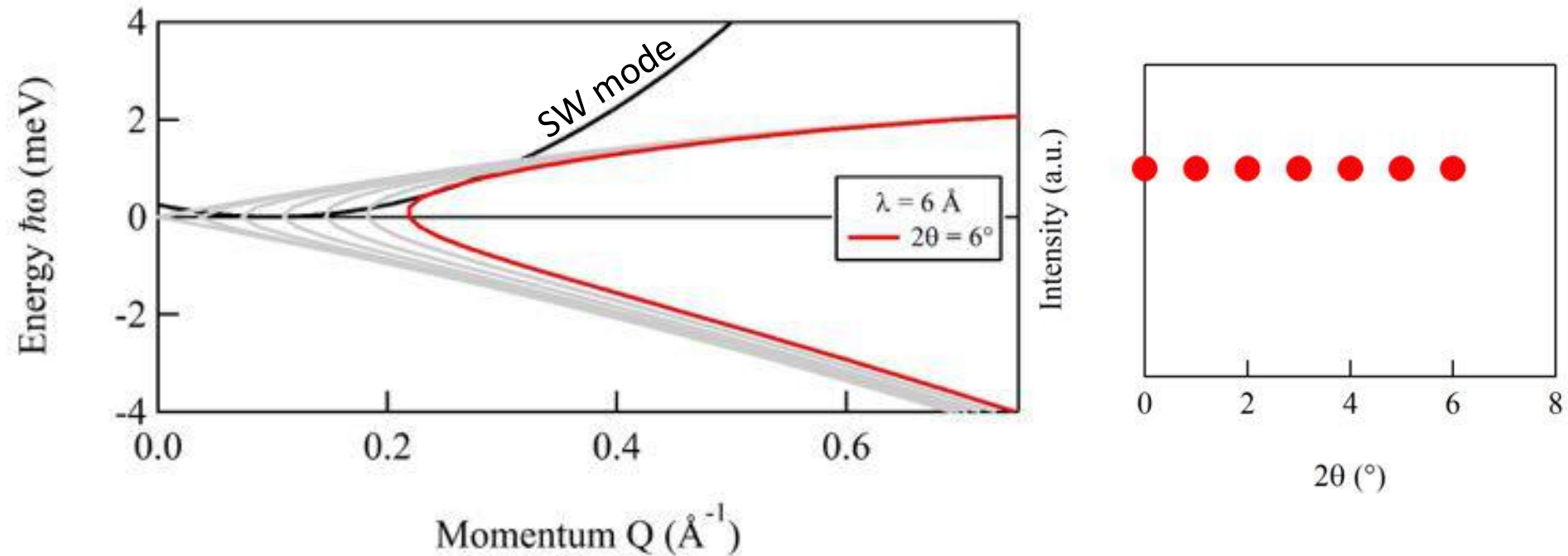

Inelastic scattering

Measurement of spin wave stiffness

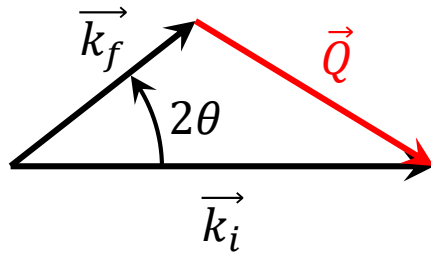

+ energy conservation

=

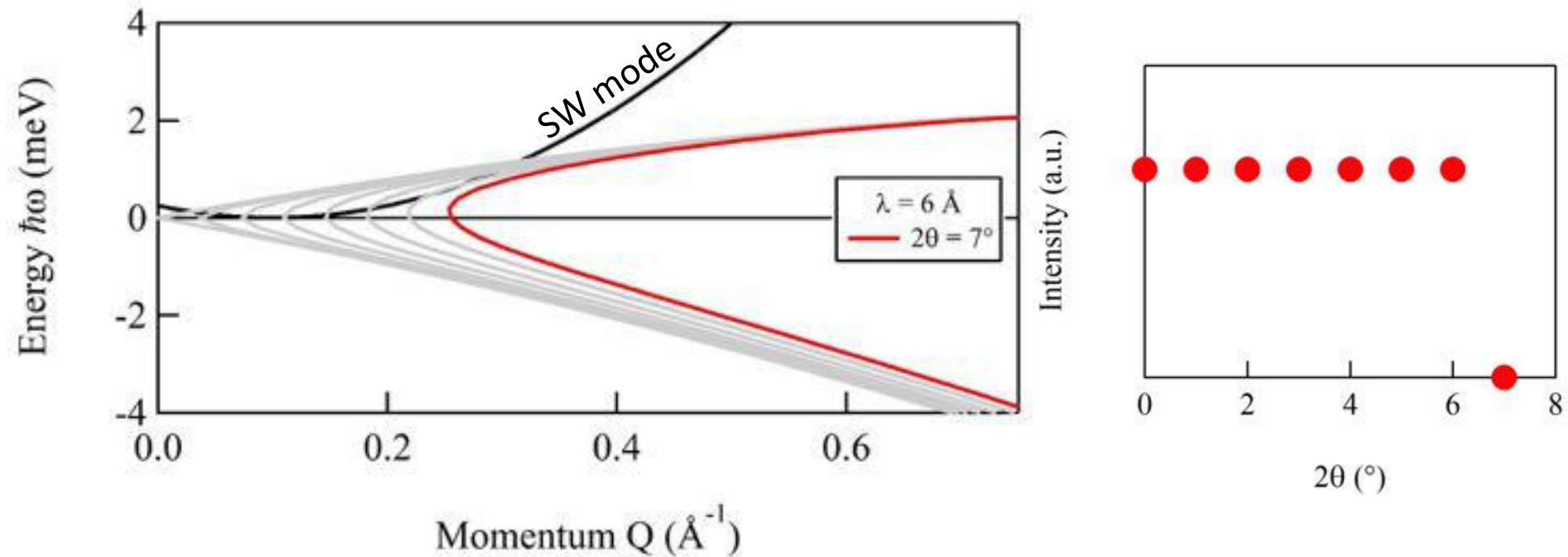

Inelastic scattering

Measurement of spin wave stiffness

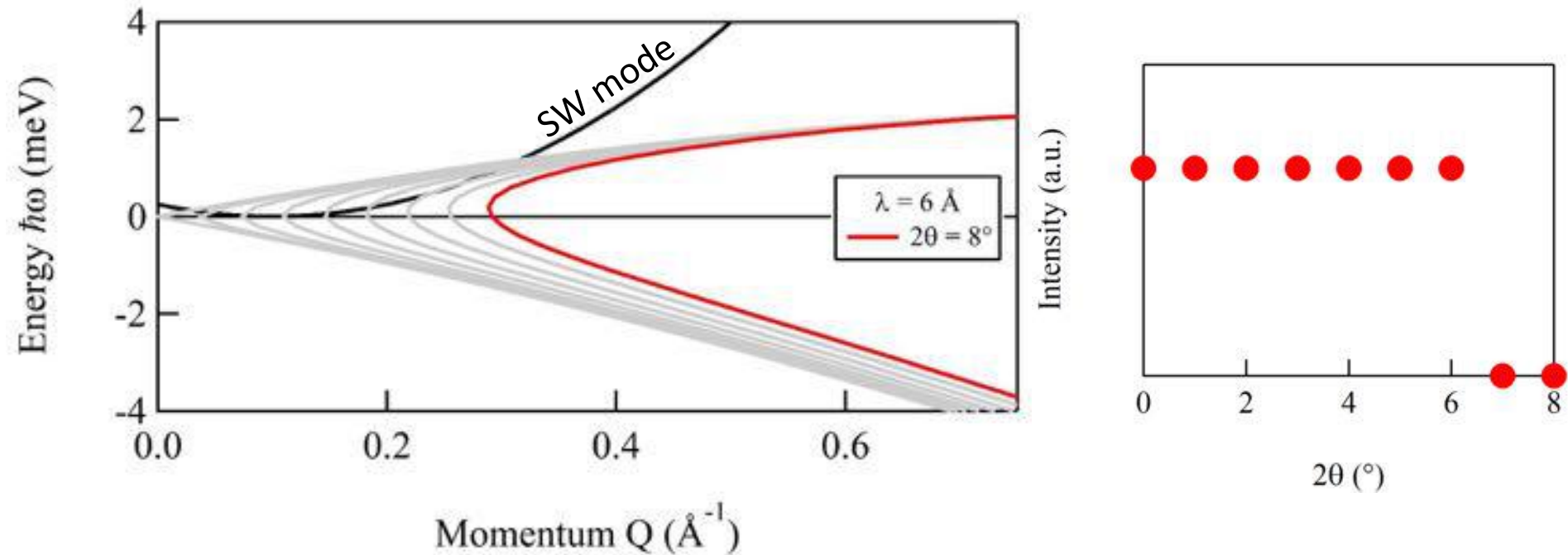
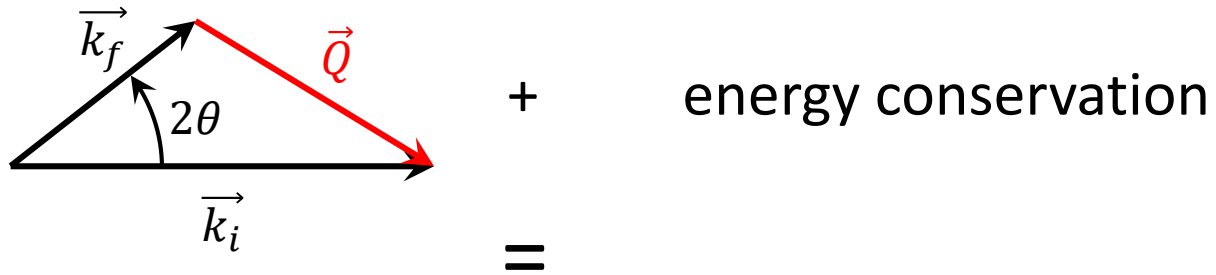

Inelastic scattering

Measurement of spin wave stiffness

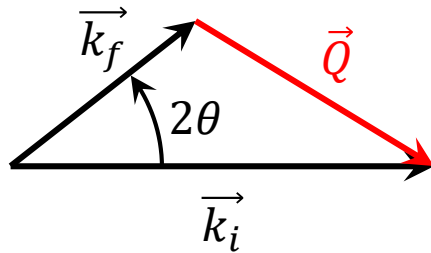

+ energy conservation

=

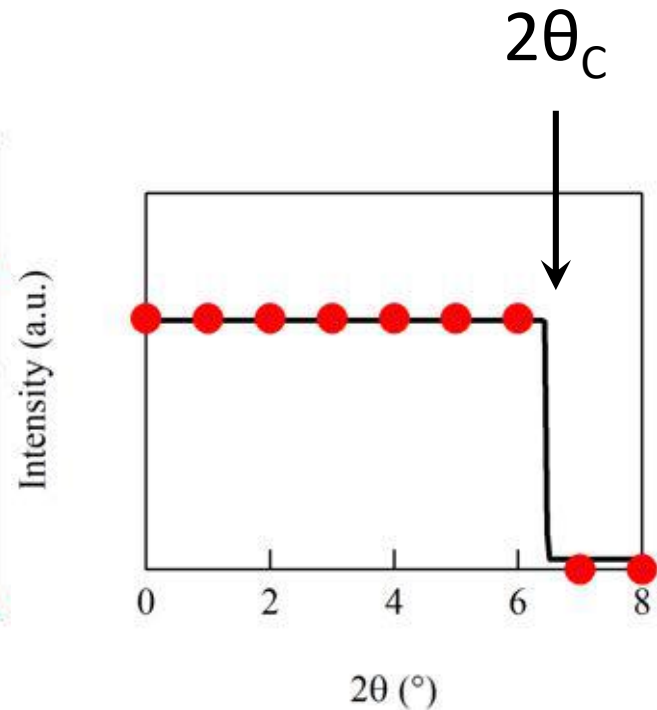
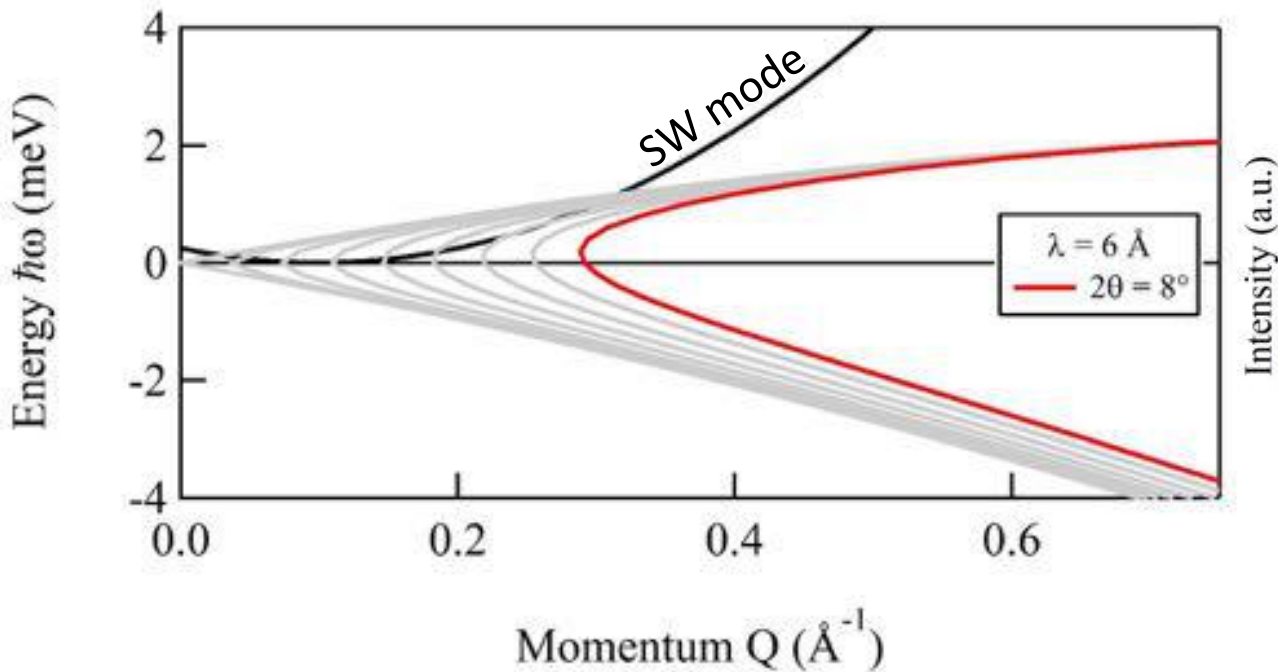

Inelastic scattering

Measurement of spin wave stiffness

- On $\text{Mn}_{0.97}\text{Fe}_{0.03}\text{Si}$:

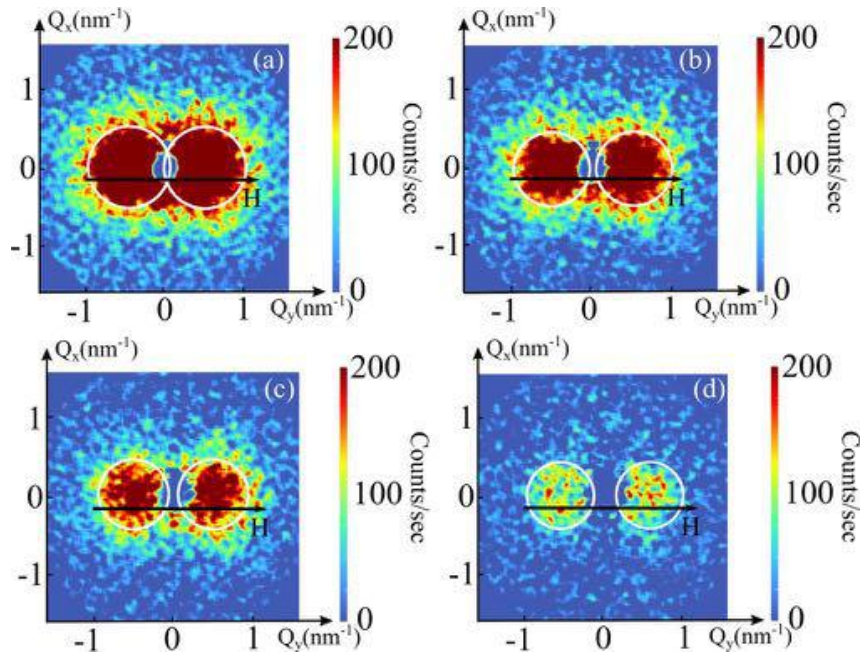

$H = 1.1 \text{ T}$

$H = 1.8 \text{ T}$

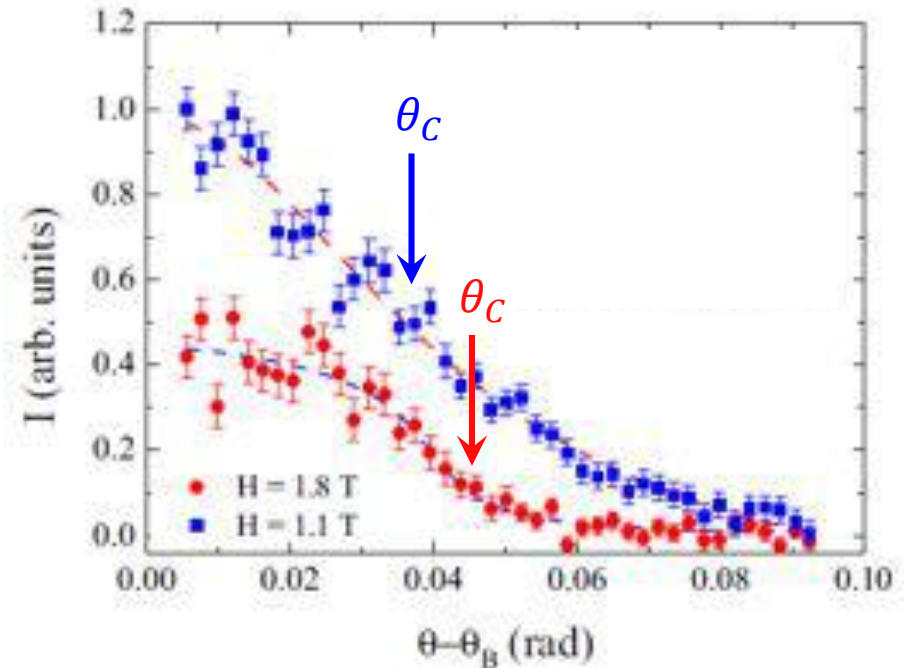

$$\theta_c^2 = \theta_0^2 - \frac{\theta_0}{E_i} H + \theta_B^2$$

where $\theta_0 = \frac{\hbar^2}{2Am_n}$

with $m_n =$ neutron mass
 $A =$ SW stiffness

$E_i =$ incident neutron energy

Inelastic scattering

Measurement of spin wave stiffness

Pure MnSi

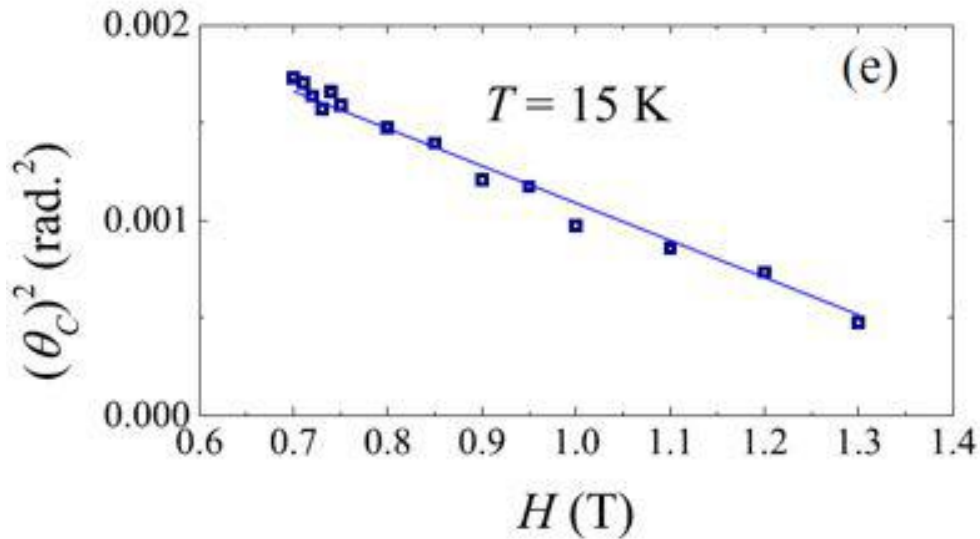

$$\theta_C^2 = \theta_0^2 - \frac{\theta_0}{E_i} H + \theta_B^2$$

Mn_{1-x}Fe_xSi series

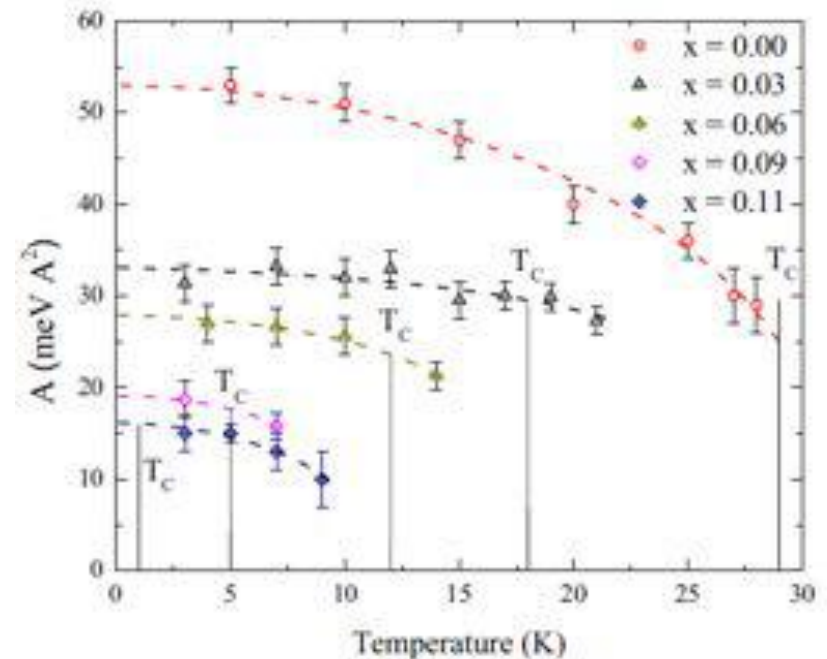

SANS for 'hard condensed matter'

Content of the talk

1. Magnetic (small angle) neutron scattering
2. Small angle diffraction
3. Magnetic form factor measurement
4. Inelastic scattering
5. Advanced SANS techniques

Advanced SANS techniques

Spin Echo Small Angle Neutron Scattering (SESANS)

- Sees what's inside the beam stop
- Polarized neutron technique → Polarization as a function of applied magnetic field:

$$P(B) \approx G(\mathbf{r}) = \int d^2Q S(\mathbf{Q}) \cos(\mathbf{Q} \cdot \mathbf{r})$$



Th. Rekveldt, Delft



SESANS instrument @ TU Delft



LARMOR instrument @ ISIS

Advanced SANS techniques

Spin Echo Small Angle Neutron Scattering (SESANS)

→ Increases SANS length scale up to 10 μm !

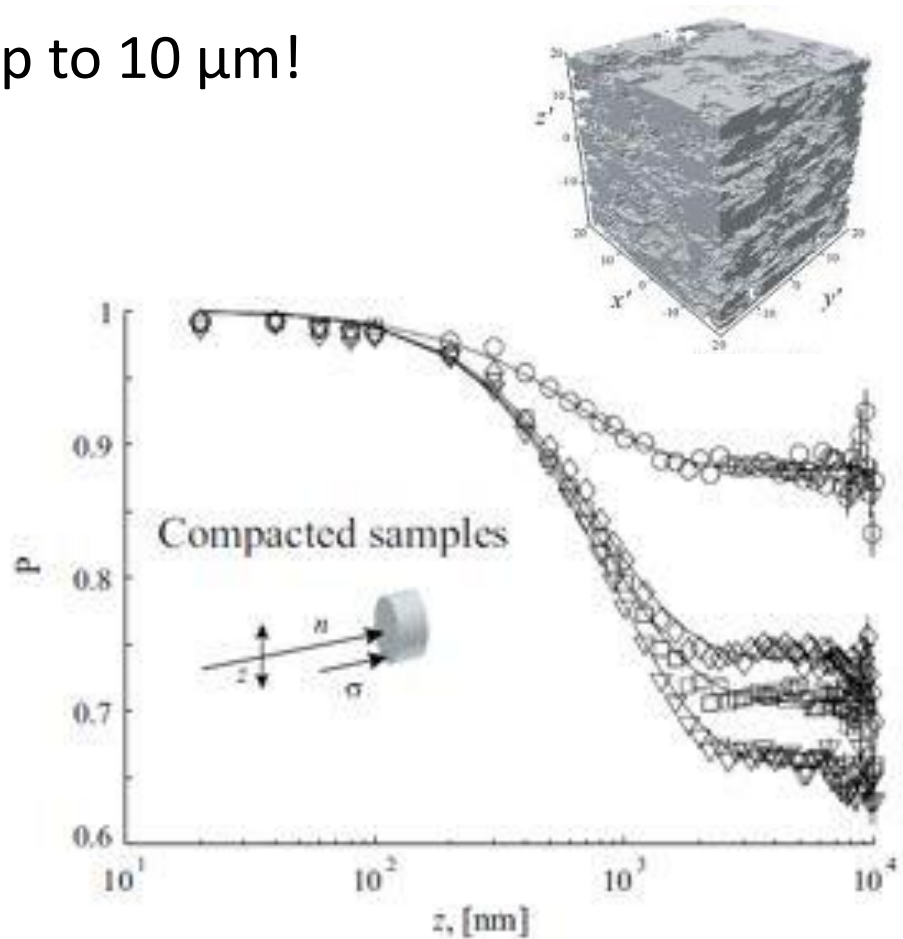
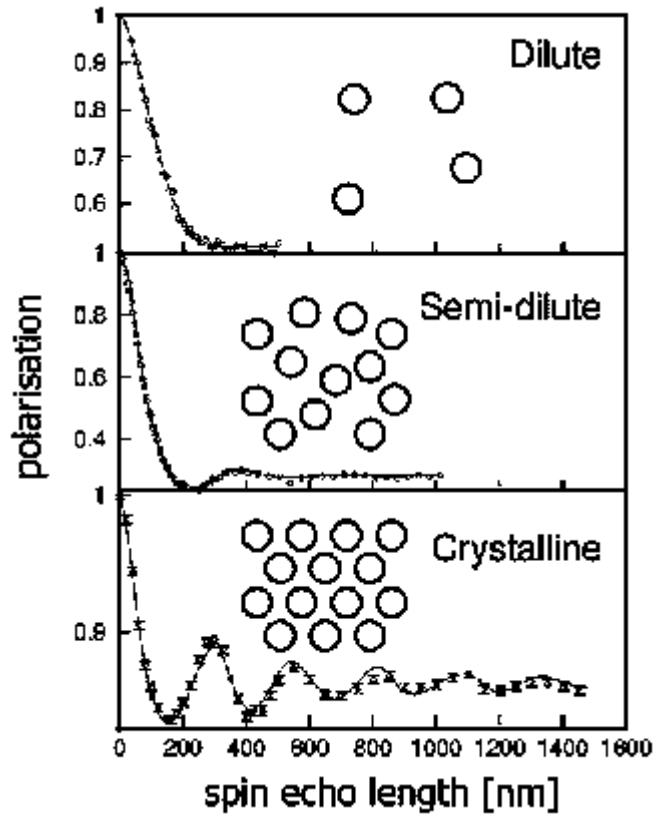

Advanced SANS techniques

Modulation of Intensity Emerging with Zero Effort (MIEZE)

- Quasi-elastic spectroscopy @ sub- μeV resolution

The incoming polarized neutron beam is manipulated by a pair of radio-frequency (RF) spin flippers running at frequencies ω_1 and ω_2 \rightarrow oscillation of neutrons' spin at a frequency $\omega_M = 2 \cdot (\omega_2 - \omega_1)$



R. Gähler, ILL

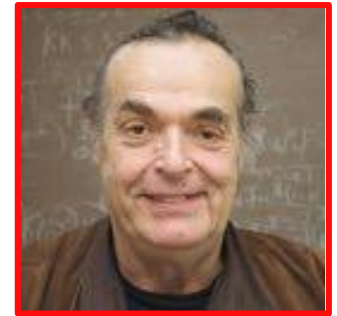

R. Golub, HMI
(now NYC University)

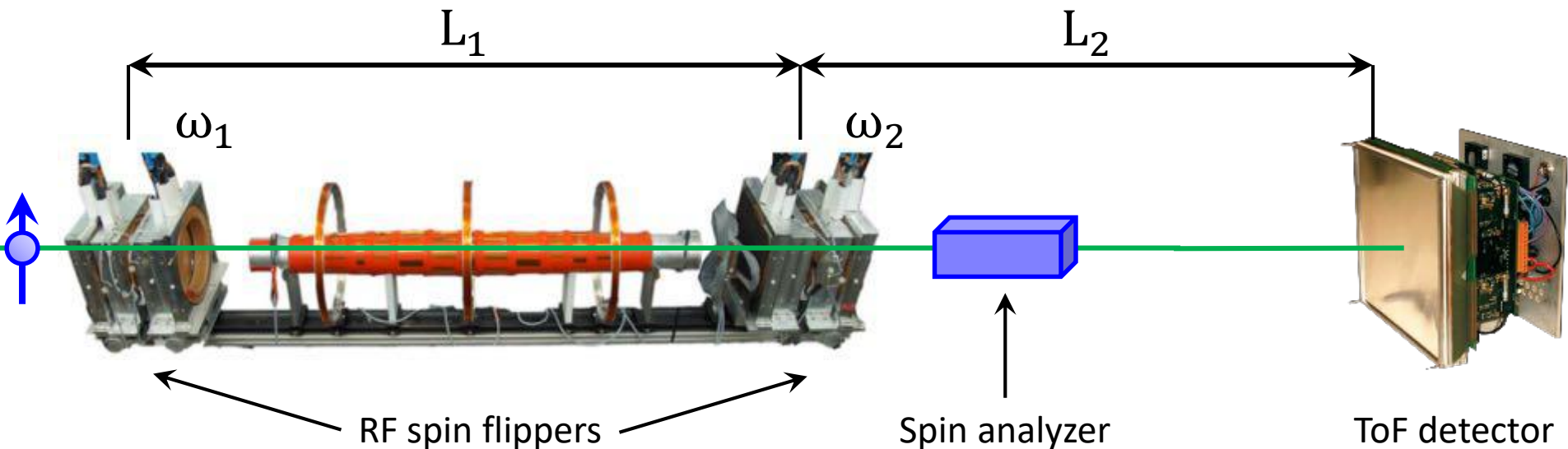

Advanced SANS techniques

Modulation of Intensity Emerging with Zero Effort (MIEZE)

- Quasi-elastic spectroscopy @ sub- μeV resolution

This time-dependent precession is converted into an **intensity modulation** by the spin analyzer.



R. Gähler, ILL

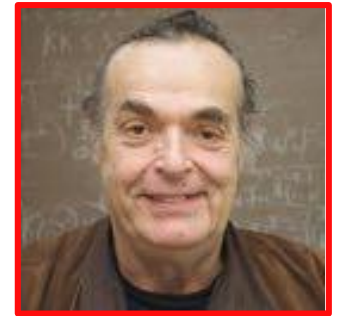

R. Golub, HMI
(now NYC University)

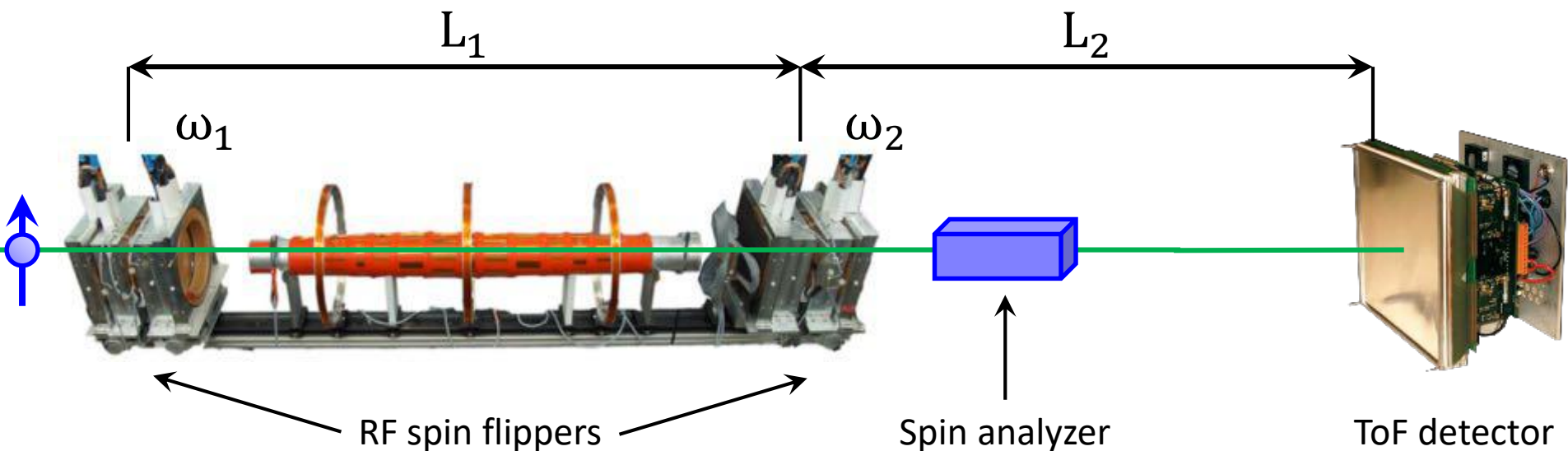

Advanced SANS techniques

Modulation of Intensity Emerging with Zero Effort (MIEZE)

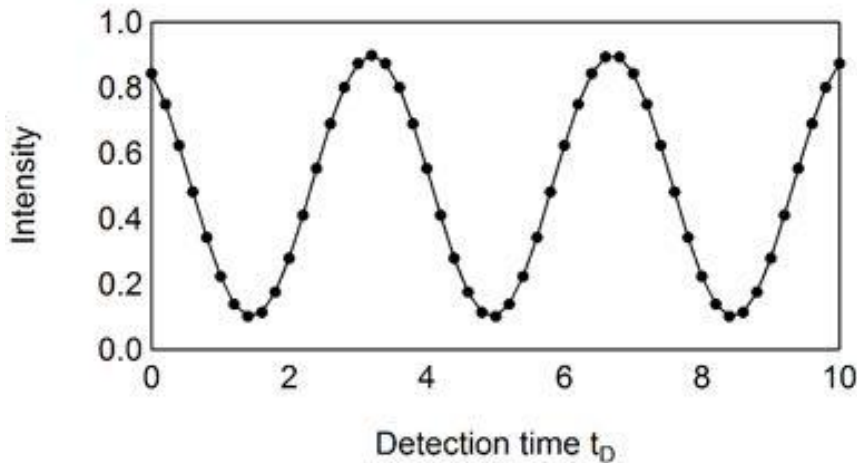
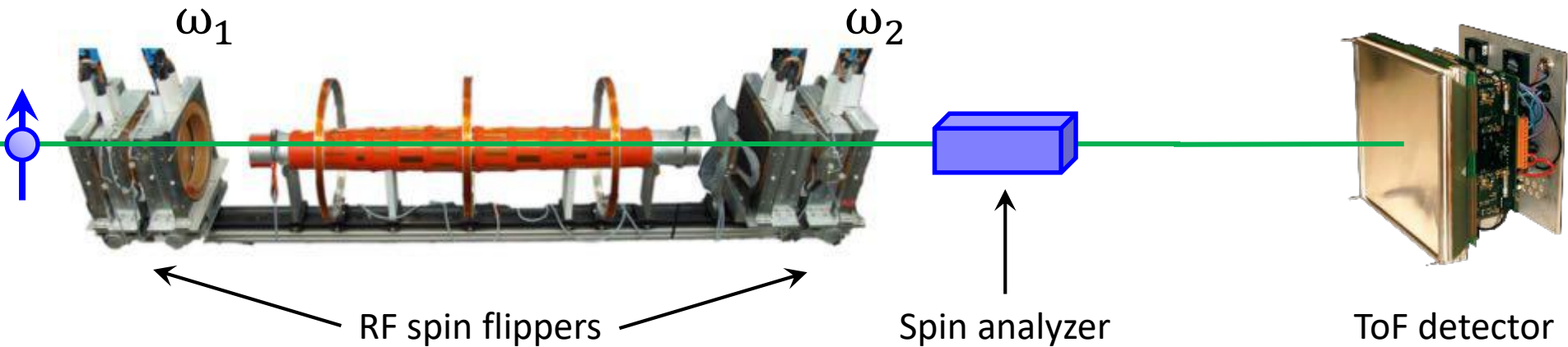

No scattering → harmonic intensity modulation at the detector

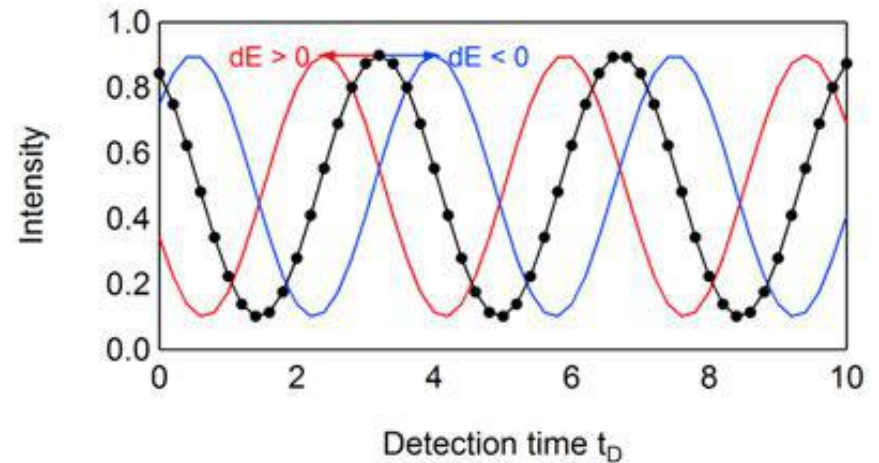

Quasi-/inelastic scattering process at the sample → distribution of neutron propagation time

Advanced SANS techniques

Modulation of Intensity Emerging with Zero Effort (MIEZE)

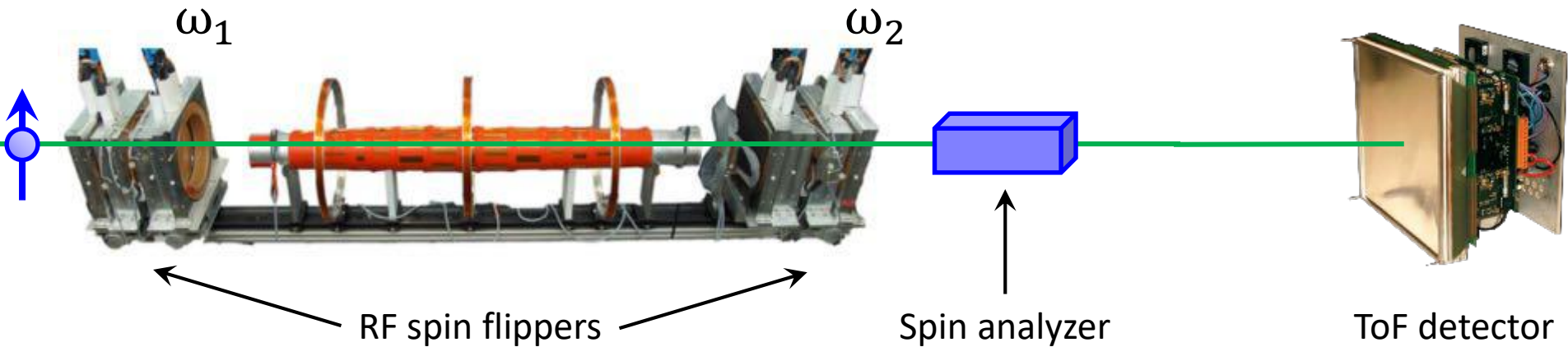

→ Signal contrast proportional to $S(q, \tau)$ i.e. the time-Fourier transform of the scattering function $S(q, \omega)$

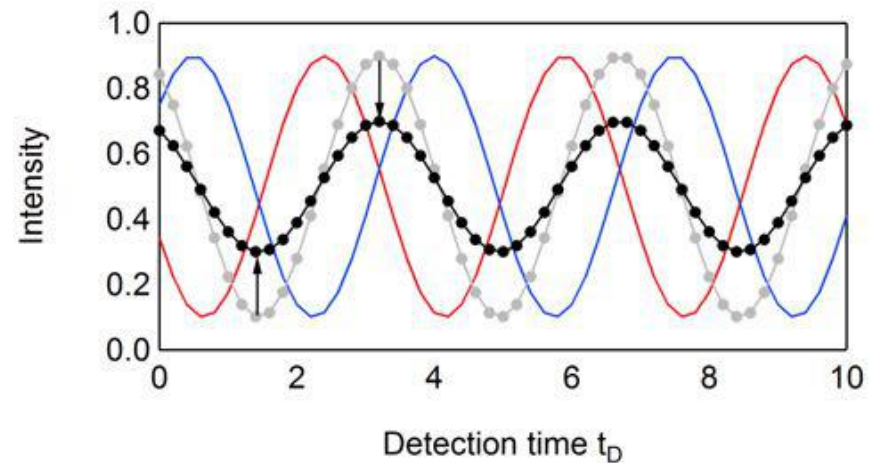

Advanced SANS techniques

Modulation of Intensity Emerging with Zero Effort (MIEZE)

- Quasi-elastic spectroscopy @ sub- μeV resolution



- The Fourier time τ (proportional to ω_M and $\bar{\lambda}^3$) quantifies the time/energy resolution. It can reach the 100 ns –range, which corresponds to a few neV resolution
- Unlike ‘traditional’ neutron spin echo (NSE) spectroscopy, MIEZE is insensitive to beam depolarization at the sample position. One can achieve high resolution under large magnetic fields, with protonated or magnetically disordered samples, *etc.*

city)

The 'SAM' project

A new SANS beamline for the French community

- ✓ **SAM** is a **S**mall **A**ngle **M**ulti-purpose instrument, meant to serve the large community of 'soft' and 'hard' matter scientists. It will be a medium size SANS instrument, with dimensions similar to that of PAXY @ LLB.

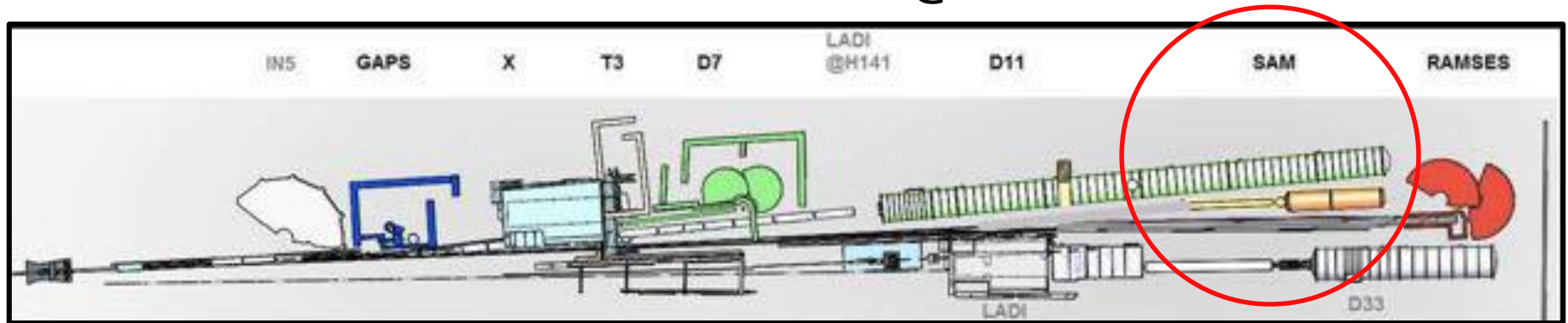

- ✓ **SAM** will embark a MIEZE module in the last part of its collimator to allow for high-resolution dynamic measurements under extreme conditions

Conclusions

- ✓ **SANS is the most versatile neutron scattering technique**
- ✓ **SANS allows measurement of the *statics* and *dynamics* of magnetic materials:**
 - Structure of long-range ordered magnets and lattices of topological defects
 - Form factor of magnetic objects with arbitrary shape
 - Spin dynamics of helical magnets or ferromagnets in powder/amorphous form
- ✓ **Technical developments/addons to a SANS spectrometer:**
 - SESANS → increase length scale up to 10 μm
 - MIEZE → dynamics of large scale structures in the 100 ns regime
 - but also ToF-SANS, stroboscopic experiments, TISANE, *etc.*

J. Appl. Cryst. (1974). 7, 96

Neutron Small-Angle Scattering: Experimental Techniques and Applications

BY W. SCHMATZ, T. SPRINGER AND J. SCHELLEN

Institut für Festkörperforschung, Kernforschungsanlage, 517 Jülich, Germany (BRD)

AND K. IBEL

Institut Max v. Laue-Paul Langevin, 38 Grenoble, France

(Received 15 October 1973; accepted 15 October 1973)

REVIEWS OF MODERN PHYSICS

[Recent](#) [Accepted](#) [Authors](#) [Referees](#) [Search](#) [Press](#) [About](#) [a](#)

Accepted Paper

Magnetic small-angle neutron scattering

Rev. Mod. Phys.

Sebastian Mühlbauer, Dirk Honecker, Élio A. Périgo, Frank Bergner, Sabrina Disch, André Heinemann, Sergey Erokhin, Dmitry Berkov, Chris Leighton, Morten Ring Eskildsen, and Andreas Michels

Accepted 12 October 2018

J. Appl. Cryst. (1974). 7, 96

Neutron Small-Angle Scattering: Experimental Techniques and Applications

BY W. SCHMATZ, T. SPRINGER AND J. SCHELLEN

Institut für Festkörperforschung, Kernforschungsanlage, 517 Jülich, Germany

AND K. IBEL

Institut Max v. Laue-Paul Langevin, 22000 Saint-Germain-lès-Bains, France

(Received 15 October 1973)

Thanks for your attention!

REVIEWS OF

Books

Press: About: 

Small-angle neutron scattering

by Susan Möhlbauer, Dirk Honecker, Élio A. Périgo, Frank Bergner, Sabrina Disch, André Heinemann, Sergey Erokhin, Dmitry Berkov, Chris Leighton, Morten Ring, Eskildsen, and Andreas Michels

Accepted 12 October 2018